

SBC

User Manual



VESTA

Single Board Computer
with the NXP i.MX 8X Processors
on 3.5" form factor



www.seco.com

REVISION HISTORY

| Revision | Date | Note | Ref |
|----------|-------------------------------|-----------------------------------|-----|
| 1.0 | 9 th December 2021 | First Official Release. | SO |
| 1.1 | 10 th August 2022 | Minor syntax corrections | SO |
| 1.2 | 31 st August 2022 | Electrical characteristics update | SO |

All rights reserved. All information contained in this manual is proprietary material of SECO S.p.A.

Unauthorized use, duplication, or modification by any means without prior consent of SECO S.p.A. is prohibited.

Every effort has been made to ensure the accuracy of this manual. However, SECO S.p.A. accepts no responsibility for any inaccuracies, errors or omissions herein. SECO S.p.A. reserves the right to change precise specifications without prior notice to supply the best product possible.

For further information on this module or other SECO products, but also to get the required assistance for any and possible issues, please contact us using the dedicated web form available at <http://www.seco.com> (registration required).

Our team is ready to assist.

INDEX

| | | |
|------------|-----------------------------------|----|
| Chapter 1. | INTRODUCTION | 5 |
| 1.1 | Warranty | 6 |
| 1.2 | Information and assistance | 7 |
| 1.3 | RMA number request | 7 |
| 1.4 | Safety | 8 |
| 1.5 | Electrostatic discharges | 8 |
| 1.6 | RoHS compliance | 8 |
| 1.7 | Safety Policy | 9 |
| 1.8 | Terminology and definitions | 10 |
| 1.9 | Reference specifications | 12 |
| Chapter 2. | OVERVIEW | 13 |
| 2.1 | Introduction | 14 |
| 2.2 | Technical specifications | 15 |
| 2.3 | Electrical specifications | 16 |
| 2.3.1 | Power requirement | 16 |
| 2.3.2 | RTC Battery | 16 |
| 2.3.3 | Power rails | 17 |
| 2.3.4 | Power consumption | 17 |
| 2.4 | Mechanical specifications | 18 |
| 2.5 | Block diagram | 19 |
| Chapter 3. | CONNECTORS | 20 |
| 3.1 | Introduction | 21 |
| 3.2 | Connectors overview | 22 |
| 3.2.1 | Connector List | 22 |
| 3.2.2 | Jumpers List | 22 |
| 3.3 | Connectors description | 23 |
| 3.3.1 | Gigabit Ethernet connectors | 23 |
| 3.3.2 | On board WiFi + BT modules | 24 |
| 3.3.3 | Audio Interfaces | 24 |
| 3.3.4 | LVDS connector | 25 |
| 3.3.5 | Panel voltage selectors | 26 |
| 3.3.6 | eDP Connector | 27 |

| | | |
|------------|-------------------------------------|----|
| 3.3.7 | Optional LED Driver Connector | 28 |
| 3.3.8 | I2C Touch Screen Connector | 28 |
| 3.3.9 | MIPI-CSI2 Connector | 29 |
| 3.3.10 | USB Connectors..... | 30 |
| 3.3.11 | Mini PCI-e Slot..... | 32 |
| 3.3.12 | CAN Connector | 33 |
| 3.3.13 | Debug Uarts Connectors | 33 |
| 3.3.14 | I/O Connectors | 34 |
| 3.3.15 | JTAG Connector | 35 |
| 3.3.16 | Power and Reset buttons..... | 35 |
| 3.3.17 | Power and Reset Connector | 35 |
| Chapter 4. | APPENDICES..... | 36 |
| 4.1 | Thermal Design..... | 37 |

Chapter 1. INTRODUCTION

- Warranty
- Information and assistance
- RMA number request
- Safety
- Electrostatic discharges
- RoHS compliance
- Safety Policy
- Terminology and definitions
- Reference specifications



1.1 Warranty

This product is subject to the Italian Law Decree 24/2002, acting European Directive 1999/44/CE on matters of sale and warranties to consumers.

The warranty on this product lasts for 1 year.

Under the warranty period, the Supplier guarantees the buyer assistance and service for repairing, replacing or credit of the item, at the Supplier's own discretion.

Shipping costs that apply to non-conforming items or items that need replacement are to be paid by the customer.

Items cannot be returned unless previously authorized by the supplier.

The authorization is released after completing the specific form available on the web-site <https://www.seco.com/it/support/online-rma.html> (RMA Online). The RMA authorization number must be put both on the packaging and on the documents shipped with the items, which must include all the accessories in their original packaging, with no signs of damage to, or tampering with, any returned item.

The error analysis form identifying the fault type must be completed by the customer and has must accompany the returned item.

If any of the above-mentioned requirements for RMA is not satisfied, the item will be shipped back and the customer will have to pay any and all shipping costs.

Following a technical analysis, the supplier will verify if all the requirements, for which a warranty service applies, are met. If the warranty cannot be applied, the Supplier will calculate the minimum cost of this initial analysis on the item and the repair costs. Costs for replaced components will be calculated separately.



Warning!

All changes or modifications to the equipment not explicitly approved by SECO S.p.A. could impair the equipment's functionalities and could void the warranty.

1.2 Information and assistance

What do I have to do if the product is faulty?

SECO S.p.A. offers the following services:

- SECO website: visit <http://www.seco.com> to receive the latest information on the product. In most of the cases it is possible to find useful information to solve the problem.
- SECO Sales Representative: the Sales Rep can help to determine the exact cause of the problem and search for the best solution.
- SECO Help-Desk: contact SECO Technical Assistance. A technician is at disposal to understand the exact origin of the problem and suggest the correct solution.

E-mail: technical.service@seco.com

Fax (+39) 0575 350210

- Repair center: it is possible to send the faulty product to the SECO Repair Centre. In this case, follow this procedure:
 - Returned items must be accompanied by an RMA Number. Items sent without the RMA number will be not accepted.
 - Returned items must be shipped in an appropriate package. SECO is not responsible for damages caused by accidental drop, improper usage, or customer neglect.

Note: Please have the following information before asking for technical assistance:

- Name and serial number of the product;
- Description of Customer's peripheral connections;
- Description of Customer's software (operative system, version, application software, etc.);
- A complete description of the problem;
- The exact words of every kind of error message encountered.

1.3 RMA number request

To request an RMA number, please visit SECO's web-site. On the home page, please select "CONTACT US" then "Online RMA" and follow the procedure described.

An RMA Number will be sent within 1 working day (only for on-line RMA requests).

1.4 Safety

The board uses only extremely-low voltages.

While handling the board, please use extreme caution to avoid any kind of risk or damages to electronic components.



Always switch the power off, and unplug the power supply unit, before handling the board and/or connecting cables or other boards.

Avoid using metallic components - like paper clips, screws and similar - near the board when connected to a power supply, to avoid short circuits due to unwanted contacts with other board components.

If the board has become wet, never connect it to any external power supply unit or battery.

Check carefully that all cables are correctly connected and that they are not damaged.

1.5 Electrostatic discharges

The board, like any other electronic product, is an electrostatic sensitive device: high voltages caused by static electricity could damage some or all the devices and/or components on-board.



Whenever handling the board, ground yourself through an anti-static wrist strap. Placement of the board on an anti-static surface is also highly recommended.

1.6 RoHS compliance

The board is designed using RoHS compliant components and is manufactured on a lead-free production line. It is therefore fully RoHS compliant.

1.7 Safety Policy

In order to meet the safety requirements of EN62368-1:2014 standard for Audio/Video, information and communication technology equipment, the board shall be:

- used exclusively with limited power sources, which cannot exceed 100W even in fault conditions;
- used along with CPU Heat-spreader/heatsinks designed according to the thermal characteristics indicated in the par. 2.2 and to the mechanical characteristics indicated in par. 2.4.
- installed inside an enclosure compliant to all applicable requirements of the above-mentioned standard;
- installed in a way that prevents the access to the board from children

The manufacturer which includes the board in his end-user product shall:

- verify the compliance with B.2 and B.3 clauses of the EN62368-1 standard when the module works in its own final operating condition.
- provide an instructional safeguard against thermal injuries, according to clause 9.4.2 of the above mentioned standard. This instructional safeguard must be placed both on end-user product's User Manual and on the product itself (Danger Label, it must be placed near the CPU or its heatsink).

The board shall be powered by a Power Supply Unit separately approved and classified ES1/PS2 according to the requirements of IEC EN 62368-1.

1.8 Terminology and definitions

| | |
|----------|--|
| API | Application Program Interface, a set of commands and functions that can be used by programmers for writing software for specific Operating Systems |
| CAN Bus | Controller Area network, a protocol designed for in-vehicle communication. |
| DDR | Double Data Rate, a typology of memory devices which transfer data both on the rising and on the falling edge of the clock. |
| eDP | embedded Display Port, a type of digital video display interface developed especially for internal connections between boards and digital displays. |
| FFC/FPC | Flexible Flat Cable / Flat Panel Cable |
| GbE | Gigabit Ethernet |
| Gbps | Gigabits per second |
| GND | Ground |
| GPI/O | General purpose Input/Output |
| I2C Bus | Inter-Integrated Circuit Bus, a simple serial bus consisting only of data and clock line, with multi-master capability |
| I2S Bus | Inter-Integrated Circuit Sound Bus, a serial bus used for connecting digital audio devices together |
| LPDDR4 | Low Power DDR, 4th generation |
| LVDS | Low Voltage Differential Signaling, a standard for transferring data at very high speed using inexpensive twisted pair copper cables, usually used for video applications |
| Mbps | Megabits per second |
| MMC/eMMC | MultiMedia Card / embedded MMC, a type of memory card, having the same interface as the SD card. The eMMC is the embedded version of the MMC. They are devices that incorporate the flash memories on a single BGA chip. |
| N.A. | Not Applicable |
| N.C. | Not Connected |
| OpenCL | Open Computing Language, a software library based on C99 programming language, conceived explicitly to realise parallel computing using Graphics Processing Units (GPU) |
| OpenVG | Open Vector Graphics, an Open Source API dedicated to hardware accelerated 2D vector graphics |
| OS | Operating System |
| OTG | On-the-Go, a specification that allows to USB devices to act indifferently as Host or as a Client, depending on the device connected to the port. |
| PCI-e | Peripheral Component Interface Express |
| PHY | Abbreviation of Physical, it is the device implementing the Physical Layer of ISO/OSI-7 model for communication systems |
| PSU | Power Supply Unit |

| | |
|--------|--|
| PWM | Pulse Width Modulation |
| PWR | Power |
| RGMI | Reduced Gigabit Reduced Media Independent Interface, a standard interface between the Ethernet Media Access Control (MAC) and the Physical Layer (PHY) |
| SD | Secure Digital, a memory card type |
| SDHC | Secure Digital Host Controller |
| SIM | Subscriber Identity Module, a card which stores all data of the owner necessary to allow him accessing to mobile communication networks |
| SM Bus | System Management Bus, a subset of the I2C bus dedicated to communication with devices for system management, like a smart battery and other power supply-related devices |
| SNVS | Secure non-volatile storage |
| SPI | Serial Peripheral Interface, a 4-Wire synchronous full-duplex serial interface which is composed of a master and one or more slaves, individually enabled through a Chip Select line |
| TBM | To be measured |
| T/S | Touch Screen |
| UIM | User Identity Module, an extension of SIM modules. |
| USB | Universal Serial Bus |
| uSDHC | Ultra Secure Digital Host Controller |
| V_REF | Voltage reference Pin |

1.9 Reference specifications

Here below it is a list of applicable industry specifications and reference documents.

| Reference | Link |
|------------------------|---|
| CAN Bus | https://www.iso.org/standard/63648.html |
| eDP | http://www.vesa.org |
| Gigabit Ethernet | https://www.ieee802.org/3/ |
| I2C | https://www.nxp.com/docs/en/user-guide/UM10204.pdf |
| I2S | https://www.sparkfun.com/datasheets/BreakoutBoards/I2SBUS.pdf |
| LVDS | https://www.ti.com/lit/an/snla165/snla165.pdf and https://www.ti.com/lit/ug/snla187/snla187.pdf |
| MMC/eMMC | https://www.jedec.org/committees/jc-64 |
| NXP i.MX 8X processors | i.MX 8X Arm Cortex A35 Cortex M4F NXP |
| OpenGL | http://www.opengl.org |
| OpenVG | http://www.khronos.org/openvg |
| SM Bus | http://www.smbus.org/specs |
| USB 2.0 and USB OTG | https://www.usb.org/sites/default/files/usb_20_20190524.zip |
| Mini-PCI Express | PCISIG - Mini Card Electromechanical Specification Revision 2.1 |

Chapter 2. OVERVIEW

- Introduction
- Technical specifications
- Electrical specifications
- Mechanical specifications
- Block diagram

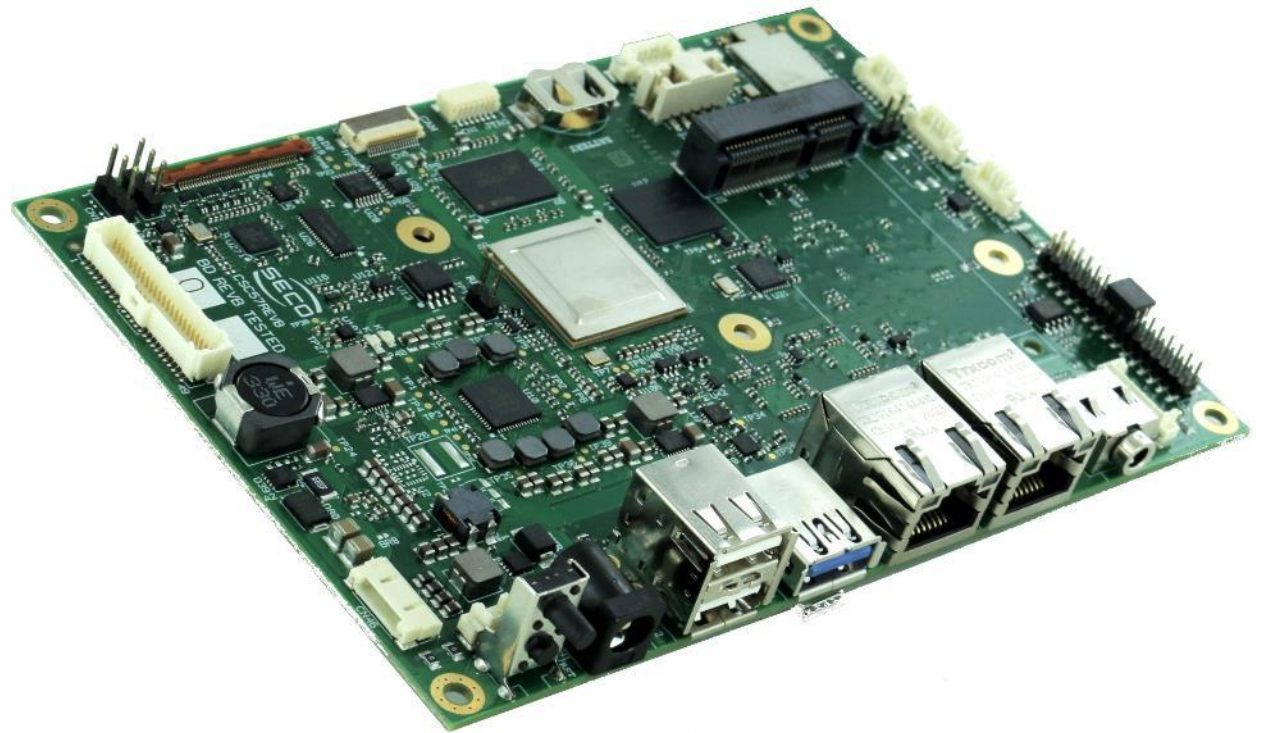

2.1 Introduction

VESTA is a Single Board Computer in 3.5" form factor (which is 146 x 102mm) based on embedded NXP i.MX 8X Applications Processors, featuring ARM® Cortex®-A35 processors, Dual- or Quad- Core + general purpose Cortex®-M4F processor, with frequencies up to 1.2GHz, which are ideal for applications requiring multimedia capabilities.

Graphics features of the board are managed directly by NXP i.MX8X processor, which integrates a GC7000Lite GPU supporting the most common standards (i.e. OpenGL 3.0; OpenGL ES 3.1; OpenCL 1.2; OpenVG 1.1; and others) and a distinct VPU for HW video decoding of the most common standards (i.e., H.265, H.264, VP8, and others) also supporting H.264 encoding.

The processor has also an integrated Tensilica® HiFi 4 DSP audio processor for efficient execution of audio codecs and voice recognition and the board mounts on-board a Texas Instrument TLV320 I2S Stereo Audio Codec, for high quality audio implementation.

The board is completed with up to 4GB LPDDR4-3200 32-bit bus memory directly soldered on board and one eMMC 5.1 Flash Drive with up to 64GB of capacity.

The board can support 24 bit Single/Dual Channel LVDS interface, and as a factory configuration option, one eDP interface is also available. Touch Screen drivers can be interfaced using the dedicated USB or I2C header connectors.

The processor offers an RGMII interface which, through two dedicated TI DP83867 Ethernet Transceivers, allows the implementation of two Gigabit Ethernet interfaces. While the first Gigabit Ethernet interface come standard with the board, the second one is optional.

The networking capabilities of this module are extended by an optional WiFi 802.11 a/b/g/n/ac + BT 5.0 NGFF module soldered on-board.

The board offers two USB 2.0 and one USB 3.0 standard Type-A connectors, an internal header with an additional USB 2.0 Host port dedicated to Touch Screen driver connection, and an USB 2.0 OTG port on micro-AB connector for use in combination with Recovery mode.

A MIPI-CSI2, 4 lanes, is present for connection of a camera module, which is directly interfaced to the NXP i.MX8X processor Imaging Submodule.

An on board PCI-express port gen3 is present on a mini PCI-e connector to host a radio module or for expansion of peripherals.

Three internal connectors complete the functionalities of this board. On these connectors, managed as factory options, it is possible to find CAN ports, processors debug UARTs and GPIOs.

The board is available both in commercial and in industrial temperature range.

Please refer to following chapter for a complete list of all peripherals integrated and characteristics.

2.2 Technical specifications

Processors

NXP i.MX 8X Family based on ARM® Cortex®-A35 cores + general purpose Cortex®-M4F 264MHz processor:

- i.MX 8QuadXPlus - Full featured, 4x Cortex®-A35 cores, up to 1.2GHz
- i.MX 8DualXPlus - Full featured, 2x Cortex®-A35 cores, up to 1.2GHz
- i.MX 8QuadXPlus - 4x Cortex®-A35 cores, up to 1.2GHz – no DSP
- i.MX 8DualXPlus - 2x Cortex®-A35 cores, up to 1.2GHz – no DSP

Memory

Soldered Down LPDDR4 memory, 32-bit interface, up to 4GB

Graphics

Vivante GC7000Lite GPU supporting OpenGL 3.0; OpenGL ES 3.1; OpenCL 1.2; OpenVG 1.1.

Embedded VPU supporting:

- HW Decoding of HEVC/H.265, AVC/H.264, VP8
- HW Encoding of AVC/H.264

Video Interfaces

LVDS Single/Dual Channel connector and eDP connector (optional)
MIPI-CSI camera connector

Video Resolution

Up to 1920x1080p @ 60Hz

Mass Storage

Optional eMMC 5.1 Drive soldered on-board, up to 64GB

Networking

Up to 2x Gigabit Ethernet interface
Optional Shielded Ultra Small Dual Band WiFi 802.11 a/b/g/n/ac with Bluetooth 5.0 Module onboard

USB

2 x USB 2.0 Host ports on Type-A sockets
1 x USB 3.0 Host ports on Type-A socket
1 x USB 2.0 Host port header dedicated to Touch Screen driver connection
1 x USB OTG micro-AB connector for use in combination with Recovery mode

Audio

an integrated Tensilica® HiFi 4 DSP audio processor

Texas Instrument TLV320 I2S Stereo Audio Codec

TRRS Combo Audio Socket and on-board header connector

Serial ports

1x RS-232 (factory alternative to 4-wire UART)
1x RS-485 (factory alternative to 2-wire UART)
1x CAN port (factory option)
2x Debug UARTs

Other Interfaces

On I/O Connector:

- 1x PWM @3.3V
- 1x I2C interface @3.3V
- 2x ADC @1.8V
- 14x GPIOs @3.3V
- 2x GPIOs @3.3V (factory option)
- 1x GPIO @3.3V

miniPCI-e slot with x1 PCIe and USB 2.0 interface

On-board ultra-low power RTC

Watchdog

JTAG connector

Dedicated connector for I2C Touch Screen Controller Support

Optional Trust Secure Element

Power supply voltage: +12V_{DC} or +24V_{DC} (factory alternatives)

Operating temperature:

Commercial version 0°C ÷ +60°C **.

Industrial version: -40°C ÷ +85°C ** (limited to -30°C ÷ +85°C with WiFi/BT module on-board)

Dimensions: 147 x 101.6 mm (5.78" x 4.00") - 3.5" form factor

Supported Operating Systems:

Yocto

Android (planned)



*** Measured at any point of SECO standard heatsink for this product, during any and all times (including start-up). Actual temperature will widely depend on application, enclosure and/or environment. Upon customer to consider application-specific cooling solutions for the final system to keep the heatspreader temperature in the range indicated. Please also check paragraph 4.1*

2.3 Electrical specifications

Depending on voltage supply factory configuration, the board needs to be supplied only with an AC-to-12V_{DC} (minimum power rating 60W) or AC-to-24V_{DC} (minimum power rating 65W) power supply with protective earth (appliance class I).

Any selected power supply will be required to be compliant with EMC standards EN55032 class B + EN55035 and FCC Part 15B class B.

Power IN connector – CN26/CN27

| Pin | Signal |
|-----|-----------------|
| 1 | V _{IN} |
| 2 | GND |

It is possible to supply the module by using two different power connectors (factory alternatives).

The first possible power connector for V_{IN} voltage is a standard 6.4mm (internal pin, diameter 2.5 mm) DC Power Jack CN27, type Würth p/n 694108301002.

As an alternative, the possible power connector is a 2-pin PCB Terminal Block with front spring-cage connection CN26, type PHOENIX CONTACT p/n 1990973 or equivalent.

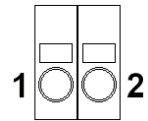
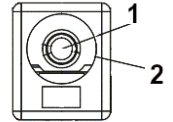

2.3.1 Power requirement

When powering the board with a PSU with characteristics greater or equal to the one described in paragraph 2.3, please consider thoroughly the use scenario of the board (i.e., which peripherals will be connected).

Since all the power must be supplied by a single external PSU, it must be cumulated the power consumption of the board itself with that of all external devices.

This way it is possible to calculate preliminarily if the PSU power rating can be sufficient for the cumulated power requirements or a more powerful PSU is required.

2.3.2 RTC Battery

The board is equipped with a low-power Real Time Clock on-board, a NXP PCF2123.

If the board is not equipped with an optional rechargeable battery, it will only be available a horizontal holder for a 3V coin cell lithium battery to supply the RTC.

The battery used is a not-rechargeable CR1225 Lithium coin-cell battery, with a nominal capacity of 48mAh, to supply such an RTC. The battery must be plugged on the onboard battery holder CN9.

In case of exhaustion, the battery should only be replaced with devices of the same type. Always check the orientation before inserting and make sure that they are aligned correctly and are not damaged or leaking.

Never allow the batteries to become short-circuited during handling.

Batteries supplied with the board are compliant to requirements of European Directive 2006/66/EC regarding batteries and accumulators. When putting out of order SBC-C43, remove the batteries from the board in order to collect and dispose them according to the requirement of the same European Directive above mentioned. Even when replacing the batteries, the disposal has to be made according to these requirements.

! CAUTION: handling batteries incorrectly or replacing with not-approved devices may present a risk of fire or explosion.

2.3.3 Power rails

In all the tables contained in this manual, the power rails are named with the following meaning:

V_{IN} : Power In voltage (in the range $+12V_{DC} \dots +24V_{DC}$) directly coming from the Power Supply connectors CN26 or CN27

+12V_ALW: $+12V_{DC}$ power rail, directly generated from V_{IN} power rail, immediately available when V_{IN} voltage is applied.

+5V_ALW: $+5V_{DC}$ power rail, directly generated from V_{IN} power rail, immediately available when V_{IN} voltage is applied.

+3V3_ALW: $+3.3V_{DC}$ power rail, directly generated from V_{IN} power rail, immediately available when V_{IN} voltage is applied.

+5V_RUN: main $+5V_{DC}$ power rail generated by the on-board PMIC.

+3V3_RUN: main $+3.3V_{DC}$ power rail generated by the on-board PMIC.

+1V8_RUN: main $+1.8V_{DC}$ power rail generated by the on-board PMIC.

+1V5_RUN: main $+1.5V_{DC}$ power rail generated from +3V3_RUN by an on-board DCDC converter.

V_{RTC} : 3V power rail for supplying the Ultra Low Power RTC

2.3.4 Power consumption

The power consumption has been measured on V_{IN} power rail using a $24V_{DC}$ source. For measurement, one configuration has been considered.

Configuration

Processor i.MX8QuadXPlus Full Featured;

RAM: 2GB LPDDR4;

Storage: 16GB eMMC;

Video Interface: eDP, LVDS + LED Driver;

Networking: 2x Gigabit LAN + WiFi with u.FL Antennas;

Expansion interfaces: 1x RS-232, 1x RS-485, 1x CAN

Other: Audio Codec

Commercial Temperature range

15.6" eDP display type BOE EV156FHM-N10 connected

| Status | Average Value (30s) | | Peak Value | |
|--------------------------------------|---------------------|-------------|------------|-------------|
| | Power (W) | Current (A) | Power (W) | Current (A) |
| OS Boot | 3.48W | 0.145A | 3.52W | 0.147A |
| OS Boot and eDP display connected | 6.792W | 0.283A | 8W | 0.335A |
| Stress test: Audio, Eth0, Eth1, Wifi | 10.2W | 0.425A | 10.3W | 0.429A |

2.4 Mechanical specifications

According to 3.5" form factor, board dimensions are: 147 x 101.6 mm (5.78" x 4.00").

The printed circuit of the board is made of ten layers, some of them are ground planes, for disturbance rejection.

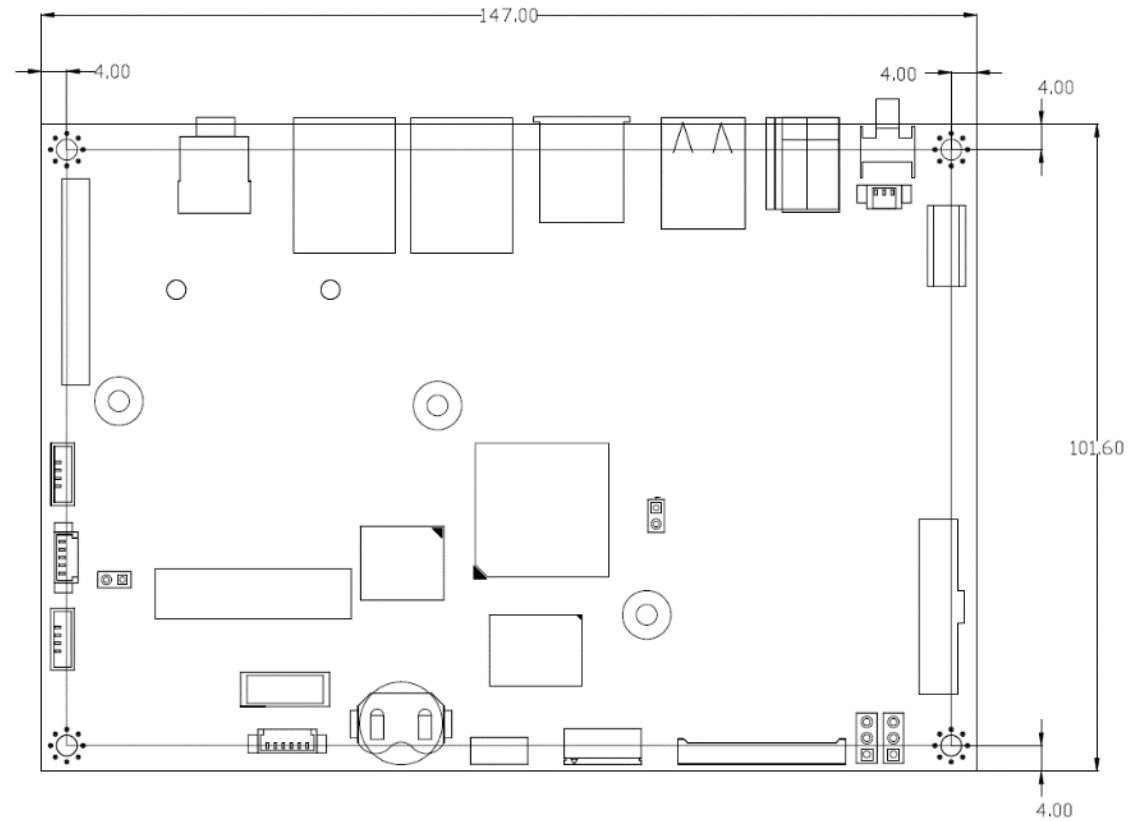

2.5 Block diagram

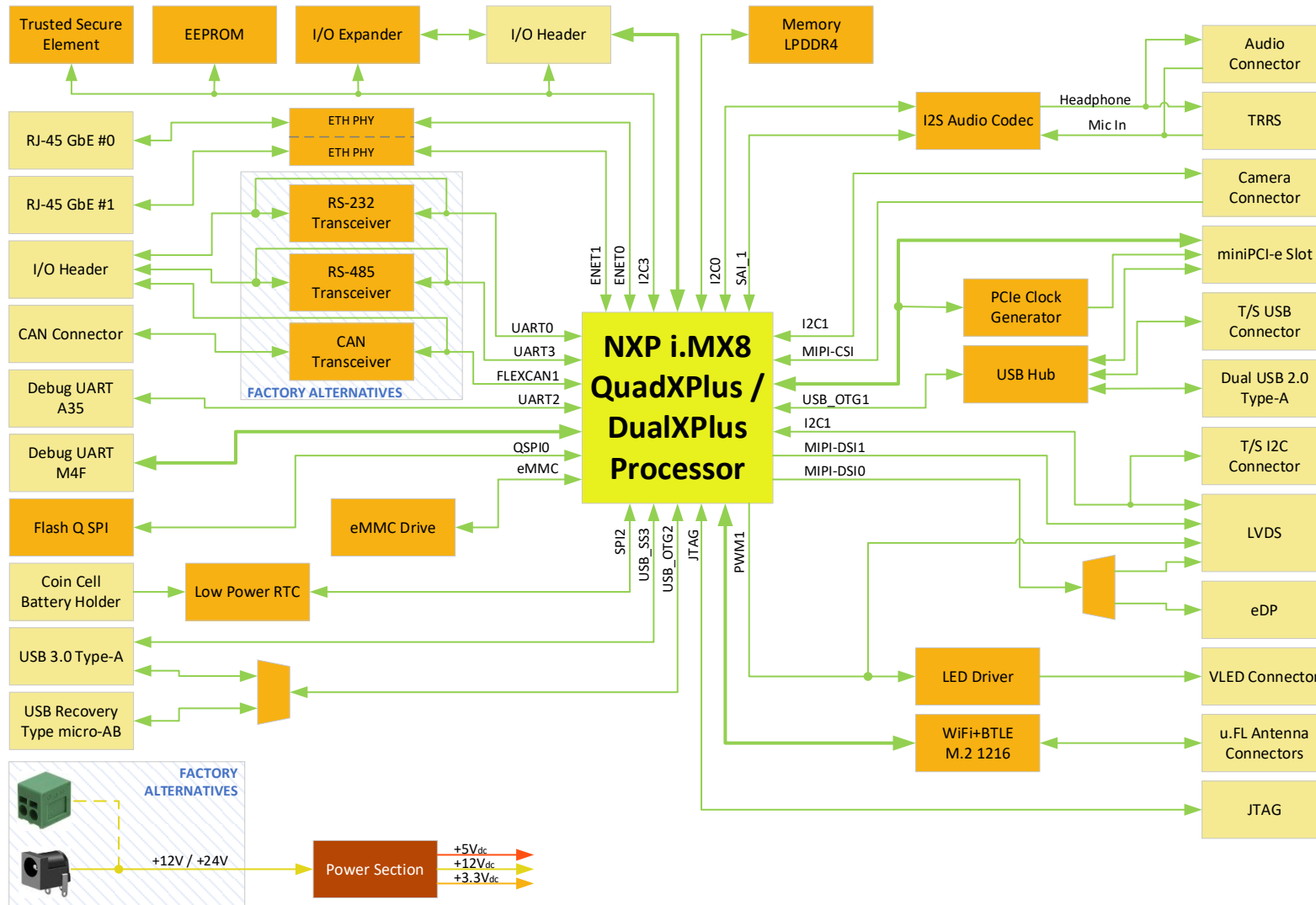

Chapter 3. CONNECTORS

- Introduction
- Connectors overview
- Connectors description

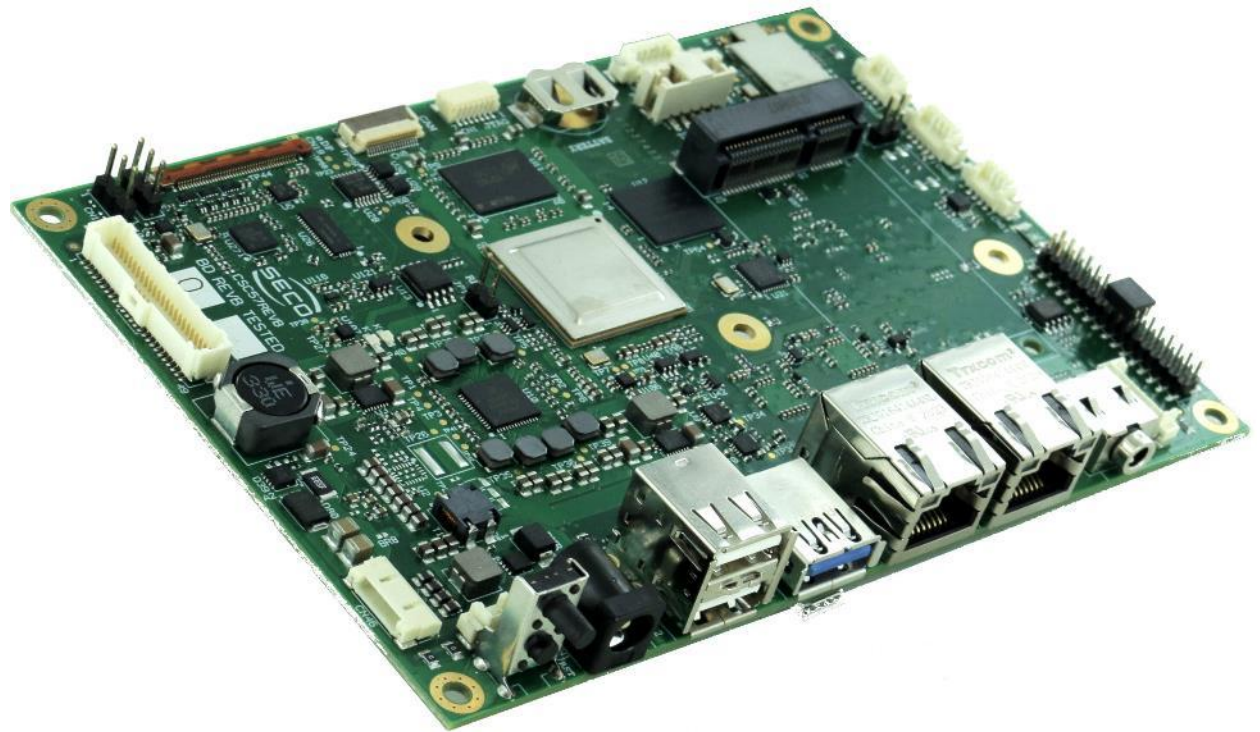

3.1 Introduction

On the board, there are several connectors located on the lower plane. Standard connectors are placed on the same side of PCB, so that it is possible to place them on a panel of an eventual enclosure.

! Please be aware that, depending on the configuration purchased, the appearance of the board could be different from the following pictures.

TOP SIDE

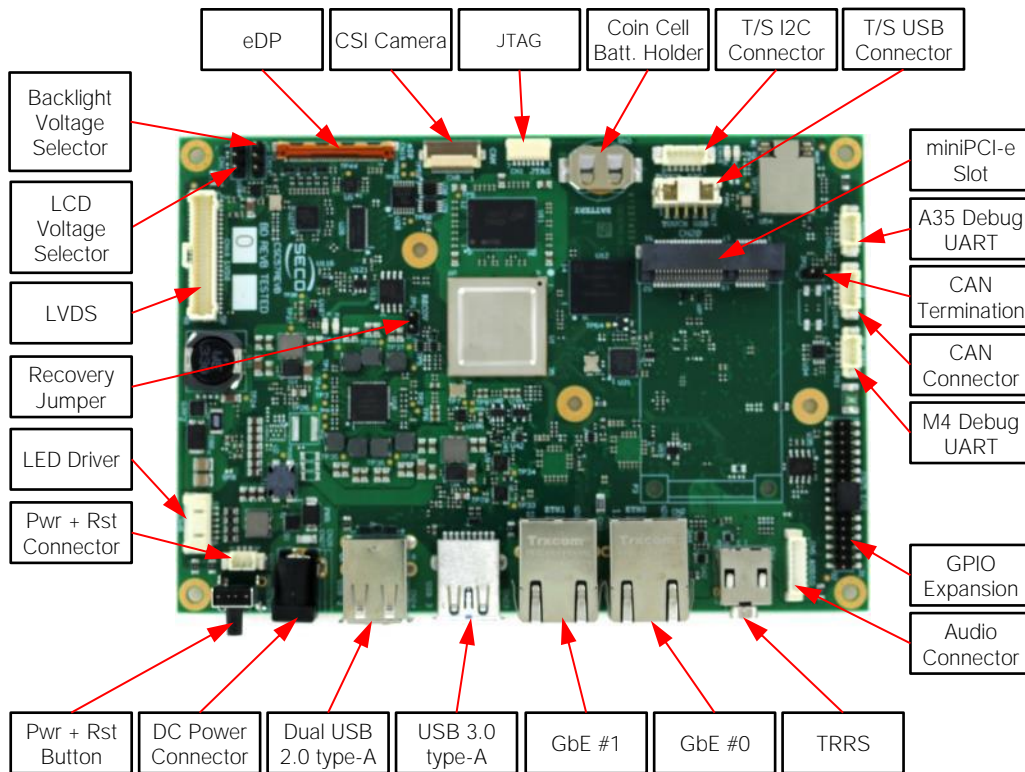

BOTTOM SIDE

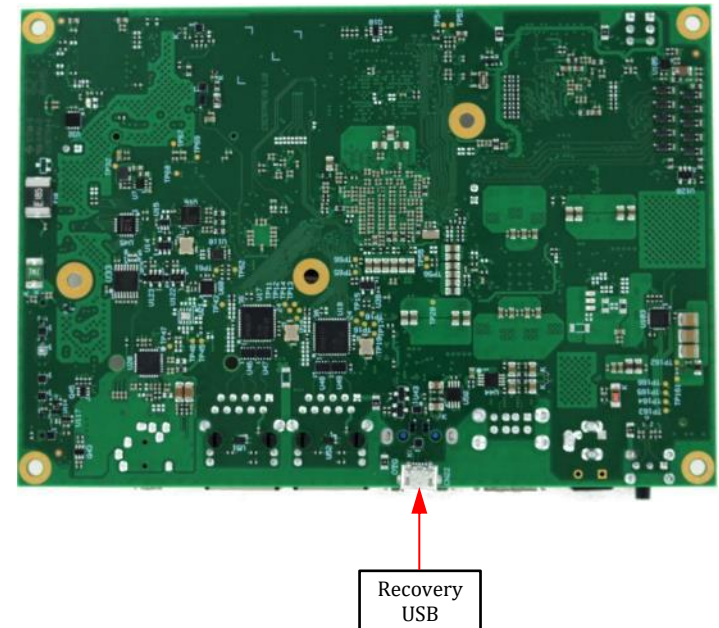

3.2 Connectors overview

3.2.1 Connector List

| Name | Description | Name | Description |
|------|--|------|--|
| CN1 | JTAG Connector (reserved for manufacturing purposes) | CN18 | LVDS Connector |
| CN2 | GbE #0 RJ-45 Connector | CN19 | eDP Connector |
| CN3 | GbE #1 RJ-45 Connector | CN20 | mini PCI-e Connector |
| CN4 | TRSS Audio Jack | CN21 | Power and Reset Header |
| CN5 | Audio Internal Header | CN22 | microUSB OTG Recovery Connector |
| CN8 | CSI Camera Connector | CN23 | USB 3.0 Host Type-A Connector |
| CN9 | CR1225 Coin Cell Battery Holder | CN24 | Dual USB 2.0 Type-A Connector |
| CN10 | CAN Bus Connector | CN25 | GPIO Expansion Header |
| CN11 | M4/SCU Debug UART Connector | CN26 | DC Power Terminals (factory alternative to CN27) |
| CN12 | A35 Debug UART Connector | CN27 | DC Power Jack |
| CN16 | T/S I2C Connector | CN46 | Led Driver Connector |
| CN17 | T/S USB Connector | | |

3.2.2 Jumpers List

| Name | Description | Name | Description |
|------|--------------------------|------|----------------------------|
| JP1 | Force Recovery | JP2 | CAN Bus Termination |
| CN13 | Display Voltage Selector | CN14 | Backlight Voltage Selector |

3.3 Connectors description

3.3.1 Gigabit Ethernet connectors

Gigabit Ethernet Port #1 – CN2

| Pin | Signal | Pin | Signal |
|-----|------------|-----|------------|
| 1 | ETH0_MDI0+ | 5 | ETH0_MDI2- |
| 2 | ETH0_MDI0- | 6 | ETH0_MDI1- |
| 3 | ETH0_MDI1+ | 7 | ETH0_MDI3+ |
| 4 | ETH0_MDI2+ | 8 | ETH0_MDI3- |

Optional Gigabit Ethernet Port #2 – CN3

| Pin | Signal | Pin | Signal |
|-----|------------|-----|------------|
| 1 | ETH1_MDI0+ | 5 | ETH1_MDI2- |
| 2 | ETH1_MDI0- | 6 | ETH1_MDI1- |
| 3 | ETH1_MDI1+ | 7 | ETH1_MDI3+ |
| 4 | ETH1_MDI2+ | 8 | ETH1_MDI3- |

On board, there are two Gigabit Ethernet connectors, for the direct connection of the board to two different wired LANs.

The Ethernet connection is realised by using two different Texas Instruments DP83867 Ethernet PHY controllers.

First connection is available on connector CN2, and is always available, The second connection, available on RJ-45 connector CN3, instead, is available only as a factory option.

The connectors are type TRXCOM p/n TRJG16314A4NL or equivalent, with 2kV decoupling capacitor, 100 Ohm impedance

This interface is compatible both with Gigabit Ethernet (1000Mbps) and with Fast Ethernet (10/100Mbps) Networks. They will configure automatically to work with the existing network.

Please be aware that Gigabit mode will work only in case Ethernet is connected to compatible switches/hubs/routers. For the connection, cables category Cat5e or better are required. Cables category Cat6 are recommended for noise reduction and EMC compatibility issues, especially when the length of the cable is significant.

On the connectors there are also two bicolor (Green /Yellow) LEDs for each port. Left LED shows 10/100 or 1000 connection: green means 100Mbps connection, yellow means 1000Mbps connection, when the left LED is Off then 10Mbps or no connection is available. The right LED blinks Green to show ACTIVITY presence

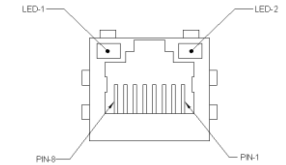

ETHx_MDI0+/ETHx_MDI0-: Ethernet Controller #x Media Dependent Interface (MDI) I/O differential pair #0. It is the Transmit differential pair in 10/100 Mbps modes, and first differential pair in Gigabit Ethernet mode.

ETHx_MDI1+/ETHx_MDI1-: Ethernet Controller #x Media Dependent Interface (MDI) I/O differential pair #1. It is the Receive differential pair in 10/100 Mbps modes, and the second differential pair in Gigabit Ethernet mode.

ETHx_MDI2+/ETHx_MDI2-: Ethernet Controller #x Media Dependent Interface (MDI) I/O differential pair #2. It is the third differential pair in Gigabit Ethernet mode (not used in 10/100Mbps modes).

ETHx_MDI3+/ETHx_MDI3-: Ethernet Controller #x Media Dependent Interface (MDI) I/O differential pair #3. It is the fourth differential pair in Gigabit Ethernet mode (not used in 10/100Mbps modes).

3.3.2 On board WiFi + BT modules

The board can be equipped with a Dual band (2.4GHz + 5.0 GHz) WLAN 802.11 ac/a/b/g/n + BT 5.0 embedded module, which is an AzureWave Type NGFF, p/n AW-CM276NF.

This optional WiFi + BT module mounts two U.FL connectors for external antennas, where BT signal is shared with WiFi signal on the Aux antenna connector.

3.3.3 Audio Interfaces

Audio Internal Header – CN5

| Pin | Signal | Pin | Signal |
|-----|-----------|-----|-------------|
| 1 | Mic_In2_L | 5 | GND |
| 2 | Mic_In2_R | 6 | Line_Out_L_ |
| 3 | Mic_In1_L | 7 | Line_Out_R |
| 4 | Mic_In1_R | 8 | GND |

The board mounts on-board a Texas Instrument TLV320 I2S Stereo Audio Codec, for high quality audio implementation.

To give the maximum flexibility to the board, it is available a dedicated 8-pin 2.54mm pitch Pin header, type Molex p/n 53398-0871, for external connection of a Line Out output and two Mic In inputs.

Mating connector: MOLEX 51021-0800 receptacle with MOLEX 50079-8000 female crimp terminals.

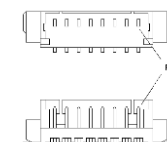

TRRS Audio Jack – CN4

| Pin | Signal |
|--------|-----------------------------|
| TIP | Headphone Out Left Channel |
| RING1 | Headphone Out Right Channel |
| RING2 | GND |
| SLEEVE | Mic In |

In order to reduce the space dedicated to connectors, there is a TRRS Combo Audio Socket CN4, i.e. a single socket which offer both stereo Line Out and Mic In functionalities.

Such TRRS Combo Audio socket can be used with any 4-poles 3.5mm diameter audio jack, with pinout compatible with the most recent Headsets, shown in the table on the left.

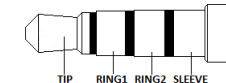

3.3.4 LVDS connector

| LVDS connector – CN18 | | | |
|-----------------------|---------------|-----|-------------|
| Pin | Signal | Pin | Signal |
| 1 | VCC_LCD | 2 | VCC_BKLT |
| 3 | VCC_LCD | 4 | VCC_BKLT |
| 5 | VCC_LCD | 6 | VCC_BKLT |
| 7 | +3V3_RUN | 8 | GND |
| 9 | GND | 10 | LVDS_A0+ |
| 11 | LVDS_A1+ | 12 | LVDS_A0- |
| 13 | LVDS_A1- | 14 | GND |
| 15 | GND | 16 | LVDS_A2+ |
| 17 | LVDS_A3+ | 18 | LVDS_A2- |
| 19 | LVDS_A3- | 20 | GND |
| 21 | GND | 22 | LVDS_A_CLK+ |
| 23 | LVDS_B0+ | 24 | LVDS_A_CLK- |
| 25 | LVDS_B0- | 26 | GND |
| 27 | GND | 28 | LVDS_B1+ |
| 29 | LVDS_B2+ | 30 | LVDS_B1- |
| 31 | LVDS_B2- | 32 | GND |
| 33 | GND | 34 | LVDS_B3+ |
| 35 | LVDS_B_CLK+ | 36 | LVDS_B3- |
| 37 | LVDS_B_CLK- | 38 | GND |
| 39 | GND | 40 | GND |
| 41 | BKLT_EN | 42 | BKLT_CTRL |
| 43 | LVDS_BKLT_ANA | 44 | LVDS_PPEN |
| 45 | TOUCH_SCL | 46 | TOUCH_RST |
| 47 | TOUCH_SDA | 48 | TOUCH_INT# |
| 49 | TOUCH_SDA | 50 | TOUCH_SCL |

The board can be interfaced to LCD displays using its LVDS interface on CN18, which allows connecting 18 or 24 bit, single or dual channel displays. This interface is implemented using a DSI to LVDS bridge (TI SN65DSI84), which allow the implementation of a Dual Channel LVDS, with a maximum supported resolution of 1920x1200 @ 60Hz (dual channel mode). Such an interface is derived from the combination of the processor's MIPI-DSI #0 (LVDS channel A) and MIPI-DSI #1 (LVDS channel B) Interfaces.

When eDP interface is present (by factory configuration) and connected, this interface can only be used in single channel mode on LVDS channel B.

For the connection, a connector type HR A1014WA-S-2x25P or equivalent (2 x 25p, male, straight, P1, low profile, polarised) is provided.

Mating connector: HR A1014H-2X25P with HR A1014-T female crimp terminals.

Alternative mating connector, MOLEX 501189-5010 with crimp terminals series 501334.

On the same connectors, are also implemented signals for direct driving of display's backlight: voltages (VCC_LCD and VCC_BKLT) and control signals (LCD Panel enable signal LVDS_PPEN, Backlight enable signal BKLT_EN, digital and analog Backlight Brightness Control signal, respectively BKLT_CTRL and LVDS_BKLT_ANA).

Output values of VCC_LCD and VCC_BKLT can be configured using jumpers as indicated in par. 3.3.5.

There are also signals necessary for driving I2C touchscreens (I2C signals, reset and interrupt request signals).

When building a cable for connection of LVDS displays, please take care of twist as tight as possible differential pairs' signal wires, in order to reduce EMI interferences. Shielded cables are also recommended.

Here following the signals related to LVDS management:

LVDS_A0+ / LVDS_A0-: LVDS Channel #0 differential data pair #0.

LVDS_A1+ / LVDS_A1-: LVDS Channel #0 differential data pair #1.

LVDS_A2+ / LVDS_A2-: LVDS Channel #0 differential data pair #2.

LVDS_A3+ / LVDS_A3-: LVDS Channel #0 differential data pair #3.

LVDS_A_CLK+ / LVDS_A_CLK-: LVDS Channel #0 differential Clock.

LVDS_B0+ / LVDS_B0-: LVDS Channel #1 differential data pair #0.

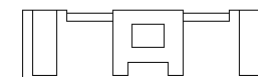
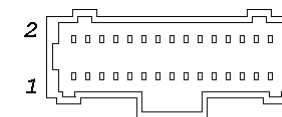

LVDS_B1+ / LVDS_B1-: LVDS Channel #1 differential data pair #1.

LVDS_B2+ / LVDS_B2-: LVDS Channel #1 differential data pair #2.

LVDS_B3+ / LVDS_B3-: LVDS Channel #1 differential data pair #3.

LVDS_B_CLK+ / LVDS_B_CLK-: LVDS Channel #1 differential Clock.

BKLT_EN: VCC_LCD electrical level Output with a 10kΩ pull-up resistor, Backlight Enable signal. It can be used to turn On/Off the backlight's lamps of connected displays.

LVDS_PPEN: VCC_LCD electrical level Output with a 10kΩ pull-up resistor, Panel Power Enable signal. It can be used to turn On/Off the connected display.

BKLT_CTRL: this signal can be used to adjust the backlight brightness in displays supporting Pulse Width Modulated (PWM) regulations (VCC_LCD electrical level).

LVDS_BKLT_ANA: Analog dimming for LVDS panel backlight, electrical level ranging from 0V up to VCC_LCD

TOUCH_SCL: I2C Bus clock line. electrical level VDD_3V3 with a 2K2Ω pull-up resistor. It is managed by the processor's I2C controller #1.

TOUCH_SDA: I2C Bus data line. Bidirectional signal, electrical level VDD_3V3 with a 2K2Ω pull-up resistor. It is managed by the processor's I2C controller #1.

TOUCH_RST: VDD_3V3 electrical level output, active high signal with a 10kΩ pull-down resistor. This signal can be used to drive a reset of an eventual external Touch Screen connected to the dedicated I2C interface.

TOUCH_INT#: VDD_3V3 electrical level input, active low signal with a 10kΩ pull-up resistor. This signal can be used to serve the interrupt request of an eventual external Touch Screen connected to the dedicated I2C interface.

3.3.5 Panel voltage selectors

Values of voltage supply for the panel (VCC_LCD) and the backlight (VCC_BKLT) can be set by using dedicated jumpers CN13 and CN14. These will both affect such voltages on the LVDS connector and on the eDP connector.

| CN13 Jumper | VCC_LCD voltage value | LCD_PWR: LCD switched voltage rail. Its value can be set to +3.3V or +5V by using dedicated jumper CN34, which is a standard pin header, P2.54mm, 1x3 pin. |
|-------------|-----------------------|--|
| 1-2 | +3V3_ALW | |
| 2-3 | +5V_ALW | |

| CN14 Jumper | VCC_BKLT voltage value | BKLT_PWR: Backlight switched voltage rail. Its value can be set to +5V or +12V by using dedicated jumper CN35, same type of CN34. This jumper is not available on boards equipped with the optional LED Driver (see par. 3.3.7) |
|-------------|------------------------|---|
| 1-2 | +12V_ALW | |
| 2-3 | +5V_ALW | |

Since the use of jumpers in environments with vibrations issues could be a problem, it is possible to provide boards with the LCD Power and Backlight Power fixed at the desired value. For this purpose, some dedicated 0-Ohm resistors can be mounted (factory default: not available). Please contact your local Sales rep in case you need this special configuration.

3.3.6 eDP Connector

| eDP connector – CN19 | | | |
|----------------------|-----------|-----|----------|
| Pin | Signal | Pin | Signal |
| 1 | --- | 21 | VCC_LCD |
| 2 | VCC_BKLT | 22 | VCC_LCD |
| 3 | VCC_BKLT | 23 | VCC_LCD |
| 4 | VCC_BKLT | 24 | GND |
| 5 | VCC_BKLT | 25 | eDP_AUX- |
| 6 | --- | 26 | eDP_AUX+ |
| 7 | --- | 27 | GND |
| 8 | BKLT_CTRL | 28 | eDP_ML0+ |
| 9 | BKLT_EN | 29 | eDP_ML0- |
| 10 | GND | 30 | GND |
| 11 | GND | 31 | eDP_ML1+ |
| 12 | GND | 32 | eDP_ML1- |
| 13 | GND | 33 | GND |
| 14 | eDP_HPD | 34 | eDP_ML2+ |
| 15 | GND | 35 | eDP_ML2- |
| 16 | GND | 36 | GND |
| 17 | GND | 37 | eDP_ML3+ |
| 18 | GND | 38 | eDP_ML3- |
| 19 | --- | 39 | GND |
| 20 | VCC_LCD | 40 | --- |

As previously stated, the board offers in addition to LVDS interface, as a factory configuration, a dedicated embedded Display Port interface. Such an interface is derived from the processor's MIPI-DSI #0 Interface.

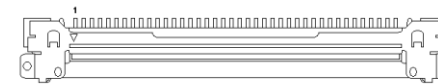

When this interface is present and connected, LVDS interface can work only in single channel mode from the processor's MIPI-DSI #1 Interface

For the connection of this kind of displays, on-board there is a VESA® certified connectors for embedded Display Port interface, type STARCONN p/n 300E40-0110RA-G3 or equivalent (microcoaxial cable connector, 0.5mm pitch, 40 positions).

On the same connectors, are also implemented signals for direct driving of display's backlight: voltages (VCC_LCD and VCC_BKLT) and control signals (BKLT_EN and BKLT_CTRL) which are shared with the LVDS connector and will affect the backlight behaviour of the LVDS panel if present (see par.3.3.4).

Output values of VCC_LCD and VCC_BKLT can be configured using jumpers as indicated in par. 3.3.5.

Here following the signals involved in eDP management:

eDP_ML0+/eDP_ML0-: embedded DP differential data pair #0.

eDP_ML3+/eDP_ML1-: embedded DP differential data pair #1.

eDP_ML3+/eDP_ML2-: embedded DP differential data pair #2.

eDP_ML3+/eDP_ML3-: embedded DP differential data pair #3.

eDP_AUX+/eDP_AUX-: embedded DP auxiliary channel differential data pair.

BKLT_EN: LCD_PWR electrical level Output with a 10kΩ pull-up resistor, Backlight Enable signal. It can be used to turn On/Off the backlight's lamps of connected displays.

BKLT_PWM: this signal can be used to adjust the backlight brightness in displays supporting Pulse Width Modulated (PWM) regulations (LCD_PWR electrical level).

3.3.7 Optional LED Driver Connector

| Backlight connector – CN46 | |
|----------------------------|---------|
| Pin | Signal |
| 1 | V_LED+ |
| 2 | V_LED+ |
| 3 | V_LED1- |
| 4 | V_LED2- |
| 5 | V_LED3- |
| 6 | V_LED4- |

The board also allow the connection of LVDS Displays requiring a dedicated LED Driver.

The functionality is implemented using an optional 4-Channel WLED controller type MPS MP3385GR-Z driven by I2C interface #3 of iMX8X processor.

Through this connector, it is possible to connect up to 4 LED strings requiring a max of 68mA per string (60V max voltage).

The connector is a 4-pin 1.25mm pitch connector, type HR P/N A1253WR-SF-06P, with the pinout indicated on the table to the left.

Mating connector: HR P/N A1253H-06P with female crimp contacts type HR P/N A1253-TPE or A1253-GPE

V_LED+: Strings' common LED Anode output (60V max voltage, generated from the driver boost circuit).

V_LEDx-: LED String x Cathode Input

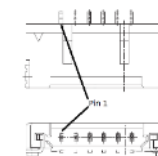

3.3.8 I2C Touch Screen Connector

| I2C Touch Connector – CN16 | |
|----------------------------|-----------|
| Pin | Signal |
| 1 | +3V3_RUN |
| 2 | TOUCH_INT |
| 3 | TOUCH_SDA |
| 4 | TOUCH_SCL |
| 5 | TOUCH_RST |
| 6 | GND |

It is possible to connect an external Touch Screen also using the dedicated connector CN16, whose pinout is described on the table to the left, instead of using the same signals available on LVDS connector CN18.

This connector is a 1.25mm pitch connector type Molex p/n 53398-0671 or equivalent.

Mating connector: MOLEX 51021-0500 receptacle with MOLEX 50079-8000 female crimp terminals.

The signals available on this connector are exactly the same available on LVDS connector CN18, for their description please see par. 3.3.4.

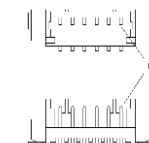

3.3.9 MIPI-CSI2 Connector

CSI Camera Connector – CN8

| Pin | Signal | Pin | Signal |
|-----|-----------------|-----|--------------------|
| 1 | MIPI_CSI0_D3_N | 10 | MIPI_CSI0_D0_N |
| 2 | MIPI_CSI0_D3_P | 11 | MIPI_CSI0_D0_P |
| 3 | MIPI_CSI0_D2_N | 12 | GND |
| 4 | MIPI_CSI0_D2_P | 13 | MIPI_CSI0_EN |
| 5 | MIPI_CSI0_D1_N | 14 | MIPI_CSI0_MCLK_OUT |
| 6 | MIPI_CSI0_D1_P | 15 | MIPI_CSI0_I2C0_SCL |
| 7 | MIPI_CSI0_CLK_N | 16 | MIPI_CSI0_I2C0_SDA |
| 8 | MIPI_CSI0_CLK_P | 17 | MIPI_CSI0_RST_B |
| 9 | GND | 18 | +3V3_RUN |

The i.MX8X family of processors includes a MIPI-CSI2, 4-lanes, camera input which can be accessed on the board through a FFC/FPC connector, type HIROSE p/n FH12-18S-0.5SH(55) which is able to accept 18 poles 0.5mm pitch FFC cables.

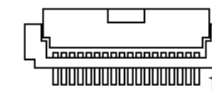

MIPI_CSI_D0_P / MIPI_CSI_D0_N: MIPI CSI Port differential data pair #0.

MIPI_CSI_D1_P / MIPI_CSI_D1_N: MIPI CSI Port differential data pair #1.

MIPI_CSI_D2_P / MIPI_CSI_D2_N: MIPI CSI Port differential data pair #2.

MIPI_CSI_D3_P / MIPI_CSI_D3_N: MIPI CSI Port differential data pair #3.

MIPI_CSI_CLK_P / MIPI_CSI_CLK_N: MIPI CSI Port differential clock pair.

MIPI_CSI_EN: External camera module Power down signal. It is an active high signal with electrical level +1.8V_RUN

MIPI_CSI_MCLK_OUT: Master Clock, electrical level +1V8_RUN. It is suggested to use camera modules with onboard crystal / oscillator and avoid using this signal. Indeed, it could cause problems for EMI compliance requirements.

MIPI_CSI_I2C0_SCL: I2C Bus clock line, Output signal, electrical level +1V8_RUN with a 2K2Ω pull-up resistor.

MIPI_CSI_I2C0_SDA: I2C Bus data line. Bidirectional signal, electrical level +1V8_RUN with a 2K2Ω pull-up resistor.

MIPI_CSI_RST_B: External camera module reset signal output, it is an active low signal.

When connecting CSI cameras to CN8 connector, it is strongly recommended to use shielded cable for EMC compatibility.

3.3.10 USB Connectors

The board offers the possibility for connecting multiple standard USB ports.

USB micro-AB Connector – CN22

| Pin | Signal |
|-----|-------------|
| 1 | +5V_USB_OTG |
| 2 | USB_OTG2_1- |
| 3 | USB_OTG2_1+ |
| 4 | USB_ID |
| 5 | GND |

A micro-AB connector for USB OTG interface is present on the bottom side of the board. An Hirose p/n ZX62D-AB-5P8 or equivalent is used, pinout is described in the table on the left.

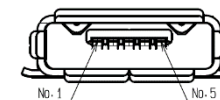

On CN22 the USB_ID pin is always left floating and +5V_USB_OTG is an input supplied by the external Host (i.e. no external device can be powered from this connector).

When a Host device is connected to connector CN22, using a micro-A or micro-B USB cable, the board configures itself to work as a Client. In case the external Host device cannot supply the +5V_USB_OTG signal, it is possible to insert a jumper in JP1 to obtain the same functionality.

USB_OTG2_1+/USB_OTG2_1-: USB OTG2 Port #1 differential pair.

+5V_USB_OTG: USB voltage rail. It is an input for USB port to enable Client mode when a Host device is connected (bypassed by jumper JP1).

USB_ID: Client/Host identification signal. This signal is always left floating.

USB 3.0 type A receptacle – CN23

| Pin | Signal | Pin | Signal |
|-----|-------------|-----|------------|
| 1 | +5V_RUN | 5 | USB_SSRX1- |
| 2 | USB_OTG2_2- | 6 | USB_SSRX1+ |
| 3 | USB_OTG2_2+ | 7 | GND |
| 4 | GND | 8 | USB_SSTX1- |
| | | 9 | USB_SSTX1+ |

When no Host device is connected to CN22 and no jumper is inserted in JP1, the same USB OTG gets set to Client mode and is carried to a standard USB 3.0 Type-A receptacle on CN23, type WELLCO p/n USB3A-0A01E001 or equivalent, with the pinout shown on the table to the left.

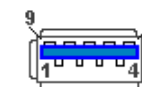

USB_OTG2_2+/USB_OTG2_2-: USB OTG2 Port #2 differential pair.

USB_SSRX1+/USB SSRX1-: USB Super Speed Port #1 receive differential pair

USB_SSTX1+/USB SSTX1-: USB Super Speed Port #1 transmit differential pair

Dual USB 2.0 Type-A Socket – CN24

| Pin | Signal | Pin | Signal |
|-----|---------|-----|---------|
| 1 | +5V_RUN | 5 | +5V_RUN |
| 2 | USB2_D- | 6 | USB3_D- |
| 3 | USB2_D+ | 7 | USB3_D+ |
| 4 | GND | 8 | GND |

A distinct USB OTG interface is carried through a Microchip USB2514 USB2.0 Hi-Speed Hub Controller, which makes available four USB 2.0 downstream host ports.

The first downstream port is carried to mini PCI-e Slot (see par. 3.3.11), the second and third are carried to CN24, a standard double USB Type-A receptacle, shielded, type ALLEN p/n HZ-002-ANW-L or equivalent.

Since this connector is a standard type-A receptacle, it can be connected to all types of USB 1.1 / USB 2.0 devices using standard-A USB 2.0 plugs

USB2+/USB2-: USB Hub Downstream port #2 differential pair.

USB3+/USB3-: USB Hub Downstream port #3 differential pair.

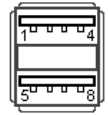

USB T/S Connector – CN17

| Pin | Signal |
|-----|---------|
| 1 | +5V_RUN |
| 2 | USB4_D- |
| 3 | USB4_D+ |
| 4 | GND |
| 5 | TS_RST# |

The fourth downstream port is used as USB host interface for T/S functionalities in case an external display panel supporting T/S via USB is used.

This interface is made available on CN17 through dedicated 5-pin 2mm pitch Pin header, type HR p/n a2001wv-s-5p, with pinout shown in the table for CN17.

Mating connector: type HR p/n a2001h-5p receptacle with HR a2001-TP female crimp terminals.

USB4+/USB4-: USB Hub Downstream port #4 differential pair.

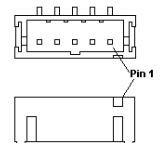

All USB ports' voltages with nomenclature +5V_{USBx} are derived, through power switches ICs, from +5V_RUN voltage.

The USB T/S port voltage is derived from +5V_RUN voltage through a resettable fuse and no power switch IC.

Common mode chokes are placed on all USB differential pairs for EMI compliance.

For ESD protection, on all data and voltage lines are placed clamping diodes for voltage transient suppression.

3.3.11 Mini PCI-e Slot

| miniPCI-e Slot – CN20 | | | |
|-----------------------|------------------------|-----|-----------|
| Pin | Signal | Pin | Signal |
| 1 | PCIE_WAKE# | 2 | +3V3_RUN |
| 3 | --- | 4 | GND |
| 5 | --- | 6 | +1V5_RUN |
| 7 | PCIE_CONN_CTRL_CLKREQ# | 8 | --- |
| 9 | GND | 10 | --- |
| 11 | PCIE_CLK- | 12 | --- |
| 13 | PCIE_CLK+ | 14 | --- |
| 15 | GND | 16 | --- |
| 17 | --- | 18 | GND |
| 19 | --- | 20 | --- |
| 21 | GND | 22 | PCIE_RST# |
| 23 | PCIE0_RX- | 24 | +3V3_ALW |
| 25 | PCIE0_RX+ | 26 | GND |
| 27 | GND | 28 | +1V5_RUN |
| 29 | GND | 30 | SMB_CLK |
| 31 | PCIE0_TX- | 32 | SMB_DAT |
| 33 | PCIE0_TX+ | 34 | GND |
| 35 | GND | 36 | USB_PCIE- |
| 37 | GND | 38 | USB_PCIE+ |
| 39 | +3.3V_RUN | 40 | GND |
| 41 | +3.3V_RUN | 42 | --- |
| 43 | --- | 44 | --- |
| 45 | --- | 46 | --- |
| 47 | --- | 48 | +1V5_RUN |
| 49 | --- | 50 | GND |
| 51 | --- | 52 | +3V3_RUN |

To add communication functionality, or other features not already available, it is possible to mount a Full-size mini-PCI Express card on connector CN20. This is a standard 52pin miniPCI Express connector with x1 PCIe and a USB 2.0 interface, type LOTES p/n AAA-PCI-047-K01 or equivalent, H=4.0mm, with the pinout shown on the table to the left.

Signals carried to miniPCI-express slot are the following:

PCIE_WAKE#: Board's Wake Input, electrical level +3V3_OUT with a 1K5Ω pull-up resistor it must be externally driven by the module inserted in the slot when it requires waking up the system.

PCIE_CONN_CTRL_CLKREQ#: PCI-e Clock Request Input. Active low signal, electrical level +3.3V_RUN with a 10KΩ pull-up resistor. This signal shall be driven low by any module inserted in the connectivity slot, in order to ensure that the SoC makes available the reference clock.

PCIE_RST#: Reset Signal that is sent from the SoC to the inserted module. It is a +3.3V_RUN active-low signal with 50kΩ pull-down.

PCIE_CLK+ / PCIE_CLK-: PCI Express Reference Clock

PCIE0_TX+ / PCIE0_TX-: PCI Express lane #0, Transmitting Output Differential pair

PCIE0_RX+ / PCIE0_RX-: PCI Express lane #0, Receiving Input Differential pair

SMB_CLK: I2C Bus clock line. Electrical level +3.3V_RUN with a 2K2Ω pull-up resistor.

SMB_DAT: I2C Bus data line. Bidirectional signal, electrical level +3.3V_RUN with a 2K2Ω pull-up resistor.

USB_PCIE- / USBPCIE+: USB Hub Downstream Port #1, differential pair

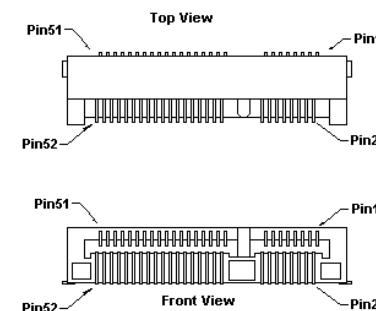

3.3.12 CAN Connector

| Can Connector – CN10 | |
|----------------------|----------|
| Pin | Signal |
| 1 | +12V_ALW |
| 2 | CAN_H |
| 3 | GND |
| 4 | CAN_L |
| 5 | --- |

This interface is compliant to CAN specifications rel. 2.0 part B. The transceiver used is designed for high-speed (up to 1Mbps) CAN applications, and also offers improved EMC and ESD performances.

CAN Bus Connector is a 5-pin single line SMT connector, type MOLEX 53398-0571 or equivalent, with pinout shown in the table on the left.

Mating connector: MOLEX 51021-0500 receptacle with MOLEX 50079-8000 female crimp terminals.

A 120Ω termination resistor can be placed between CAN_H and CAN_L signals. It can be connected or disconnected from the line by using JP2 jumper (Jumper inserted = termination connected).

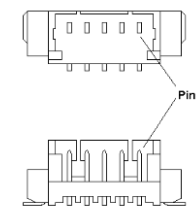

3.3.13 Debug Uarts Connectors

| M4/SCU Debug UART – CN11 | |
|--------------------------|-------------|
| Pin | Signal |
| 1 | +3V3_RUN |
| 2 | M40_UART_Rx |
| 3 | M40_UART_Tx |
| 4 | GND |

Onboard, connectors CN11 and CN12 carry out signals of UART interfaces from the i.MX8X processor.

UART on CN11 is dedicated to debugging of Cortex-M4F processors. Connector is a 4-pin, type MOLEX p/n 53398-0471 or equivalent, with pinout shown on the table to the left.

Mating connector: MOLEX 51021-0400 receptacle with MOLEX 50079-8000 female crimp terminals.

M4_UART_Rx: M4F debug UART port Receive signal, +3V3_RUN electrical level.

M4_UART_Tx: M4F debug UART port Transmit signal, +3V3_RUN electrical level.

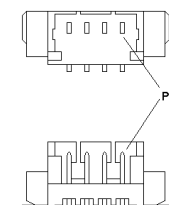

| A35 Debug UART – CN12 | |
|-----------------------|----------|
| Pin | Signal |
| 1 | +3V3_RUN |
| 2 | UART2_Rx |
| 3 | UART2_Tx |
| 4 | GND |

UART on CN12 is dedicated to debugging of Cortex-A35 processors. Connector is same type as CN11, with pinout shown on the table to the left.

UART2_Rx: A35 debug UART port Receive signal, +3V3_RUN electrical level

UART2_Tx: A35 debug UART port Transmit signal, +3V3_RUN electrical level

3.3.14 I/O Connectors

The board offers the possibility of expanding its functionalities by using some additional interfaces, available on dedicated SMT dual row 2mm Pitch, h=4mm, 32 pin connectors CN25, type Townes p/n P1022-216MGF or equivalent.



| GPIO expansion – CN25 | | | | | |
|-----------------------|------------------|------------------|-----|------------------|------------------|
| Pin | Factory Option 1 | Factory Option 2 | Pin | Factory Option 1 | Factory Option 2 |
| 1 | +5V_RUN | | 2 | +3V_RUN | |
| 3 | GND | | 4 | LSIO_GPIO3_IO00 | |
| 5 | ADC_IN0 | | 6 | ADC_IN1 | |
| 7 | GPIO_EXP_P0_1 | | 8 | GPIO_EXP_P0_2 | |
| 9 | CAN_TX | GPIO_EXP_P0_4 | 10 | CAN_RX | GPIO_EXP_P0_0 |
| 11 | RS232_CTS | UART0_CTS | 12 | RS232_TX | UART0_TX |
| 13 | RS232_RTS | UART0_RTS | 14 | RS232_RX | UART0_RX |
| 15 | GPIO_EXP_P0_5 | | 16 | GPIO_EXP_P0_6 | |
| 17 | GPIO_EXP_P0_7 | | 18 | GPIO_EXP_P1_0 | |
| 19 | GPIO_EXP_P1_1 | | 20 | GPIO_EXP_P1_2 | |
| 21 | GPIO_EXP_P1_3 | | 22 | GPIO_EXP_P1_4 | |
| 23 | GPIO_EXP_P1_5 | | 24 | I2C3_SDA | |
| 25 | I2C3_SCL | | 26 | RS485_D+ | UART3_RX |
| 27 | RS485_D- | UART3_TX | 28 | GPIO_EXP_P1_6 | |
| 29 | GPIO_EXP_P1_7 | | 30 | PWM_2 | |
| 31 | GPIO_EXP_P0_3 | | 32 | GND | |

The pinout of this connector is shown on the table to the left, next to each pin are indicated the possible uses, according to factory options.

The GPIOs present on this connector are generated by an expander managed by the processor's I2C controller #3. For these pins port numbering is written for ease of identification, each pin can be set individually and independently from the use of the other pins of the same port. These signals are protected with DRTR5V0U4LP16 TVS Diodes. All other signals are protected with D5V0F2U3LP TVS Diodes.

Here is a complete description of the interfaces made available on this connector:

LSIO_GPIO3_IO00: General purpose I/O signal managed directly from the SoC, electrical level +3V3_RUN.

GPIO_EXP_P0_x, GPIO_EXP_P1_x: General purpose I/O signals generated by the expander, electrical levels +3V3_RUN.

ADC_IN0, ADC_IN1: Analog inputs, electrical range +1V8.

CAN_TX, CAN_RX: usable CAN Bus at TTL level, available only in case the board is not configured with a dedicated CAN transceiver (see par. 3.3.12). When a CAN transceiver is installed, these pins are connected to GPIOs from the expander.

As a factory option, it is possible to have UART0 configured with TTL or RS-232 interface.

RS232_RX: COM Port #0 RS-232 Mode Receive data

RS232_TX: COM Port #0 RS-232 Mode Transmit data

RS232_RTS: COM Port #0 RS-232 Mode Request to Send handshaking

RS232_CTS: COM Port #0 RS-232 Mode Clear To Send handshaking signal

I2C3_SCL: I2C Bus clock line. Output signal, electrical level +3V3_OUT with a 2K2Ω pull-up resistor. It is managed by the processor's I2C controller #3.

I2C3_SDA: I2C Bus data line. Bidirectional signal, electrical level +3V3_RUN with a 2K2Ω pull-up resistor. It is managed by the processor's I2C controller #3.

As a factory option, it is possible to have UART3 configured with TTL or RS-485 interface.

RS485_D+/ RS485_D-: COM Port #3 RS-485 Mode, Differential Pair

PWM_2: Generic PWM output signal managed directly from the SoC, electrical level +3V3_RUN.

3.3.15 JTAG Connector

| JTAG Connector– CN1 | |
|---------------------|-----------|
| Pin | Signal |
| 1 | +1.8V_RUN |
| 2 | JTAG_TCK |
| 3 | JTAG_TMS |
| 4 | JTAG_TDI |
| 5 | JTAG_TDO |
| 6 | JTAG_RST# |
| 7 | GND |

The i.MX8X family of processors includes a System JTAG Controller (SJC) providing debug and test controls for maximum security. On the board, the JTAG interface is available on connector header CN1, type JST p/n SM07B-SRSS-TB or equivalent, with the pinout shown on the table to the left.

Mating connector: JST SHR-07V-S receptacle or equivalent with JST SSH-003T-P0.2-H female crimp terminals.

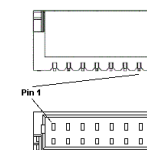

JTAG_RST#: power section reset input, active low signal, electrical level +1V8_RUN with a 10KΩ pull-up resistor

All other JTAG signals are directly connected to i.MX8X pins with same name. Please refer to i.MX8X processor's documentation for a description of the signals and their usage.

3.3.16 Power and Reset buttons

The board can offer a dual push-button Switch (P/N TS-472-DBS-BB) for the On/Off and System Reset functionalities.

When upper pushbutton is toggled the board will turn on from off and respectively turn off from on.

When the lower push button is toggled the board's power section will be reset.

Please be aware that the dual push button switch is available only on board in commercial temperature range, since it cannot sustain the full industrial temperature range.

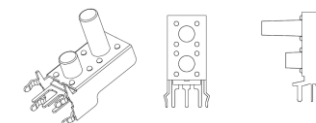

3.3.17 Power and Reset Connector

| ON/OFF and Reset Connector – CN21 | |
|-----------------------------------|--------|
| Pin | Signal |
| 1 | ONOFF |
| 2 | GND |
| 3 | RST |

Independently by the temperature range of the module purchased, it is always available an additional connector, CN21, to allow use of external power and reset switches, this is a 3-pin Connector, Type MOLEX p/n 53398-0371 or equivalent. Mating connector: MOLEX 51021-0300 receptacle with MOLEX 50079-8000 female crimp terminals.

ONOFF: input signal, pulled high at +1.8V_RUN with a 100kΩ resistor, when toggled the board will turn on from off and respectively turn off from on.

RST_BTN: input signal, pulled high at +3V3_RUN with 10kΩ resistor, when toggled the board's power section will be reset.

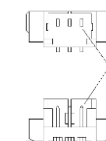

Chapter 4. APPENDICES

- Thermal Design



4.1 Thermal Design

A parameter that has to be kept in very high consideration is the thermal design of the system.

Highly integrated modules, like this product, offer to the user very good performances in minimal spaces, therefore allowing the system's minimization. On the counterpart, the miniaturizing of IC's and the rise of operative frequencies of processors lead to the generation of a big amount of heat, that must be dissipated to prevent system hang-off or faults.

The board can be used along with specific heatspreaders, but please remember that they will act only as thermal coupling device between the board itself and an external dissipating surface/cooler. The heatspreader also needs to be thermally coupled to all the heat generating surfaces using a thermal gap pad, which will optimize the heat exchange between the module and the heatspreader.

The heatspreader is not intended to be a cooling system by itself, but only as means for transferring heat to another surface/cooler, like heatsinks, fans, heat pipes and so on.

When using this product, it is necessary to consider carefully the heat generated by the part in the assembled final system, and the scenario of utilization.

Until the board is used on a laboratory shelf, on free air, just for software development and system tuning, then a heatsink with integrated fan could be sufficient for board's cooling. Anyhow, please remember that all depends also on the workload of the processor. Heavy computational tasks will generate much heat with all SOC's versions.

Therefore, it is always necessary that the customer studies and develops accurately the cooling solution for his system, by evaluating processor's workload, utilization scenarios, the enclosures of the system, the air flow and so on.

SECO can provide product specific passive heatsinks, but please remember that their use must be evaluated accurately inside the final system, and that they should be used only as a part of a more comprehensive ad-hoc cooling solutions.

| Ordering Code | Description |
|---------------|-------------------------------|
| 41D1051031100 | Heatsink unit for VESTA board |



Warning!

The thermal solutions available with SECO boards are validated and certificated according to IEC 62368-1 in the temperature range [-40°C-75°C], without housing and inside climatic chamber. Therefore, the customer is suggested to study, develop and validate the cooling solution for his system, considering ambient temperature, processor's workload, utilisation scenarios, enclosures, air flow and so on.



SECO S.p.A. - Via A. Grandi, 20
52100 Arezzo - ITALY
Ph: +39 0575 26979 - Fax: +39 0575 350210
www.seco.com