

SMARC[®]

User Manual

SOM-SMARC- MX8M-PLUS

SMARC[®] Rel. 2.1.1 compliant
module with NXP i.MX 8M Plus
Applications Processors



REVISION HISTORY

Revision	Date	Note	Rif
1.0	8 th February 2022	First official release	SO
1.1	23 rd February 2022	Minor corrections SoC to SMARC® pinout	SO
1.2	27 th September 2022	Updated SDIO electrical level for SDR104	SO
1.3	4 th March 2024	Updated to new commercial name. New manual layout. References updated. Typo corrected on signals' names on pins S17, S18, S84, S87, S90 USB5_EN_OC# signal description added QSPI_CSI# signal added	SB

All rights reserved. All information contained in this manual is proprietary material of SECO S.p.A.

Unauthorized use, duplication, or modification by any means without prior consent of SECO S.p.A. is prohibited.

Every effort has been made to ensure the accuracy of this manual. However, SECO S.p.A. accepts no responsibility for any inaccuracies, errors or omissions herein. SECO S.p.A. reserves the right to change precise specifications without prior notice to supply the best product possible.

For further information on this module or other SECO products, but also to get the required assistance for any and possible issues, please contact us using the dedicated web form available at <http://www.seco.com> (registration required).

Our team is ready to assist.

INDEX

Chapter 1.	INTRODUCTION	4
1.1	Warranty	5
1.2	Information and assistance	6
1.3	RMA number request	6
1.4	Safety	7
1.5	Electrostatic Discharges	7
1.6	RoHS compliance	7
1.7	Safety Policy	8
1.8	Terminology and definitions	9
1.9	Reference specifications	11
Chapter 2.	OVERVIEW	12
2.1	Introduction	13
2.2	Technical Specifications	14
2.3	Electrical Specifications	15
2.3.1	Power Consumption	15
2.3.2	Power Rails meanings	15
2.4	Mechanical Specifications	16
2.5	Supported Operating Systems	16
2.6	Block Diagram	17
Chapter 3.	CONNECTORS	18
3.1	Introduction	19
3.2	Connectors description	20
3.2.1	WiFi/BTLE Module	20
3.2.2	SMARC® Connector	21
Chapter 4.	Appendices	44
4.1	SoC to Connector Pinout	45
4.2	Thermal Design	51

Chapter 1. INTRODUCTION

- Warranty
- Information and assistance
- RMA number request
- Safety
- Electrostatic Discharges
- RoHS compliance
- Terminology and definitions
- Reference specifications



1.1 Warranty

This product is subject to the Italian Law Decree 24/2002, acting European Directive 1999/44/CE on matters of sale and warranties to consumers.

The warranty on this product lasts for 1 year.

Under the warranty period, the Supplier guarantees the buyer assistance and service for repairing, replacing or credit of the item, at the Supplier's own discretion.

Shipping costs that apply to non-conforming items or items that need replacement are to be paid by the customer.

Items cannot be returned unless previously authorised by the supplier.

The authorisation is released after completing the specific form available on the web-site <https://www.seco.com/us/support/online-rma.html> (RMA Online). The RMA authorisation number must be put both on the packaging and on the documents shipped with the items, which must include all the accessories in their original packaging, with no signs of damage to, or tampering with, any returned item.

The error analysis form identifying the fault type must be completed by the customer and has must accompany the returned item.

If any of the above-mentioned requirements for RMA is not satisfied, the item will be shipped back and the customer will have to pay any and all shipping costs.

Following a technical analysis, the supplier will verify if all the requirements, for which a warranty service applies, are met. If the warranty cannot be applied, the Supplier will calculate the minimum cost of this initial analysis on the item and the repair costs. Costs for replaced components will be calculated separately.



Warning!

All changes or modifications to the equipment not explicitly approved by SECO S.p.A. could impair the equipment's functionality and could void the warranty

1.2 Information and assistance

What do I have to do if the product is faulty?

SECO S.p.A. offers the following services:

- SECO website: visit <http://www.seco.com> to receive the latest information on the product. In most of the cases it is possible to find useful information to solve the problem.
- SECO Sales Representative: the Sales Rep can help to determine the exact cause of the problem and search for the best solution.
- SECO Help-Desk: contact SECO Technical Assistance. A technician is at disposal to understand the exact origin of the problem and suggest the correct solution.

E-mail: technical.service@seco.com

Fax (+39) 0575 350210

- Repair center: it is possible to send the faulty product to the SECO Repair Centre. In this case, follow this procedure:
 - Returned items must be accompanied by a RMA Number. Items sent without the RMA number will be not accepted.
 - Returned items must be shipped in an appropriate package. SECO is not responsible for damages caused by accidental drop, improper usage, or customer neglect.

Note: Please have the following information before asking for technical assistance:

- Name and serial number of the product;
- Description of Customer's peripheral connections;
- Description of Customer's software (operating system, version, application software, etc.);
- A complete description of the problem;
- The exact words of every kind of error message encountered.

1.3 RMA number request

To request an RMA number, please visit SECO's web-site. On the home page, please select "RMA Online" and follow the procedure described.

An RMA Number will be sent within 1 working day (only for on-line RMA requests).

1.4 Safety

The SOM-SMARC-MX8M-PLUS module uses only extremely low voltages.

While handling the board, please use extreme caution to avoid any kind of risk or damages to electronic components.



Always switch the power off, unplug the power supply unit and wait until the unit has cooled down, before handling the board and/or connecting cables or other boards.

Avoid using metallic components - like paper clips, screws and similar - near the board when connected to a power supply, to avoid short circuits due to unwanted contacts with other board components.

If the board has become wet, never connect it to any external power supply unit or battery.

1.5 Electrostatic Discharges

The SOM-SMARC-MX8M-PLUS module, like any other electronic product, is an electrostatic sensitive device: high voltages caused by static electricity could damage some or all the devices and/or components on-board.



Whenever handling any of these boards, ground yourself through an anti-static wrist strap. Placement of the board on an anti-static surface is also highly recommended.

1.6 RoHS compliance

The SOM-SMARC-MX8M-PLUS module is designed using RoHS compliant components and is manufactured on a lead-free production line. It is therefore fully RoHS compliant.

1.7 Safety Policy

In order to meet the safety requirements of IEC 62368-1:2018 standard for Audio/Video, information and communication technology equipment, the SOM-SMARC-MX8M-PLUS Module shall be:

- used exclusively on SMARC 2.1 fully compliant Carrier boards;
- connections from or to the Module have to be compliant to ESI requirements;
- used inside a fire enclosure made of non-combustible material or V-1 material (the fire enclosure is not necessary if the maximum power supplied to the module never exceeds 100 W, even in worst-case fault);
- used along with CPU Heatspreader/heatsinks designed according to the thermal characteristics indicated in the par. 2.2 and to the mechanical characteristics indicated in par.2.4.

The manufacturer which includes a SOM-SMARC-MX8M-PLUS module in his end-user product shall:

- Install the device inside an enclosure compliant with all applicable IEC 62368-1 requirements;
- Prevent children from accessing the board;
- Prescribe temperature and humidity range for operating, transport and storage conditions;
- verify the compliance with B.2 and B.3 clauses of the IEC 62368-1 standard when the module works in its own final operating condition;
- provide an instructional safeguard against thermal injuries, according to clause 9.5.2 of the above mentioned standard. This instructional safeguard must be placed both on end-user product's User Manual and on the products itself (Danger Label IEC 60417-5041, it must be placed near the CPU or its heatsink);
- When an heatsink with FAN is used, then the FAN should be managed with signals made available by SMARC Card Edge Connector of the SOM-SMARC-MX8M-PLUS module. Its electrical characteristics must be compliant to the requirements of SMARC Rel.2.1 standard.

1.8 Terminology and definitions

API	Application Program Interface, a set of commands and functions that can be used by programmers for writing software for specific Operating Systems
BTLE	Bluetooth Low Energy, a wireless personal area network technology
CAN Bus	Controller Area network, a protocol designed for in-vehicle communication
CSI2	MIPI Camera Serial Interface, 2nd generation standard regulating communication between a peripheral device (camera) and a host processor
DDC	Display Data Channel, a kind of I2C interface for digital communication between displays and graphics processing units (GPU)
DDR	Double Data Rate, a typology of memory devices which transfer data both on the rising and on the falling edge of the clock.
DVI	Digital Visual interface, a type of display video interface
FFC/FPC	Flexible Flat Cable / Flat Panel Cable
GBE	Gigabit Ethernet
Gbps	Gigabits per second
GND	Ground
GPI/O	General purpose Input/Output
HDMI	High Definition Multimedia Interface, a digital audio and video interface
I2C Bus	Inter-Integrated Circuit Bus, a simple serial bus consisting only of data and clock line, with multi-master capability
I2S	Inter-Integrated Circuit Sound, an audio serial bus protocol interface developed by Philips (now NXP) in 1986
LPDDR4	Low-Power Double Data Rate Synchronous Dynamic Random Access Memory, 4 th generation
LVDS	Low Voltage Differential Signalling, a standard for transferring data at very high speed using inexpensive twisted pair copper cables, usually used for video applications
Mbps	Megabits per second
MIPI	Mobile Industry Processor Interface alliance
MMC/eMMC	MultiMedia Card / embedded MMC, a type of memory card, having the same interface as the SD card. The eMMC is the embedded version of the MMC. They are devices that incorporate the flash memories on a single BGA chip.
N.A.	Not Applicable
N.C.	Not Connected
OpenGL	Open Graphics Library, an Open Source API dedicated to 2D and 3D graphics
OpenVG	Open Vector Graphics, an Open Source API dedicated to hardware accelerated 2D vector graphics

OTG	On-the-Go, a specification that allows to USB devices to act indifferently as Host or as a Client, depending on the device connected to the port.
PCI-e	Peripheral Component Interface Express
PWM	Pulse Width Modulation
PWR	Power
RGMI	Reduced Gigabit Reduced Media Independent Interface, a standard interface between the Ethernet Media Access Control (MAC) and the Physical Layer (PHY)
SD	Secure Digital, a memory card type
SDIO	Secure Digital Input/Output, an evolution of the SD standard that allows the use of the same SD interface to drive different Input/Output devices, like cameras, GPS, Tuners and so on.
SM Bus	System Management Bus, a subset of the I2C bus dedicated to communication with devices for system management, like a smart battery and other power supply-related devices.
SPI	Serial Peripheral Interface, a 4-Wire synchronous full-duplex serial interface which is composed of a master and one or more slaves, individually enabled through a Chip Select line.
TBM	To be measured
TMDS	Transition-Minimized Differential Signalling, a method for transmitting high speed serial data, normally used on DVI and HDMI interfaces
TTL	Transistor-transistor Logic
USB	Universal Serial Bus
uSDHC	Ultra Secure Digital Host Controller

1.9 Reference specifications

Here below it is a list of applicable industry specifications and reference documents.

Reference	Link
CAN Bus	https://www.iso.org/standard/63648.html
CSI	https://www.mipi.org/specifications/csi-2
DDC	http://www.vesa.org
Gigabit Ethernet	https://www.ieee802.org/3/
HDMI	http://www.hdmi.org
I2C	https://www.nxp.com/docs/en/user-guide/UM10204.pdf
I2S	https://www.sparkfun.com/datasheets/BreakoutBoards/I2SBUS.pdf
LVDS	http://www.ti.com/ww/en/analog/interface/lvds.shtml and http://www.ti.com/lit/ml/snla187/snla187.pdf
MIPI	http://www.mipi.org
MMC/eMMC	http://www.jedec.org/committees/jc-64
NXP i.MX 8M Plus processor	i.MX 8M Plus Cortex-A53/M7 NXP Semiconductors
OpenGL	http://www.opengl.org
OpenVG	http://www.khronos.org/openvg
PCI Express	http://www.pcisig.com/specifications/pciexpress
SMARC Design Guide 2.1.1	https://sget.org/wp-content/uploads/2021/05/SMARCmodule_DG_V211.pdf
SMARC Hardware Specification 2.1.1	https://sget.org/wp-content/uploads/2020/05/SMARC_V211.pdf
SD Card Association	https://www.sdcard.org/home
SDIO	https://www.sdcard.org/developers/overview/sdio
SM Bus	http://smbus.org/specs
USB 2.0 and USB OTG	https://www.usb.org/document-library/usb-20-specification
USB 3.x	https://www.usb.org/sites/default/files/usb_32_202206_0.zip

Chapter 2. OVERVIEW

- Introduction
- Technical Specifications
- Electrical Specifications
- Mechanical Specifications
- Supported Operating Systems
- Block Diagram

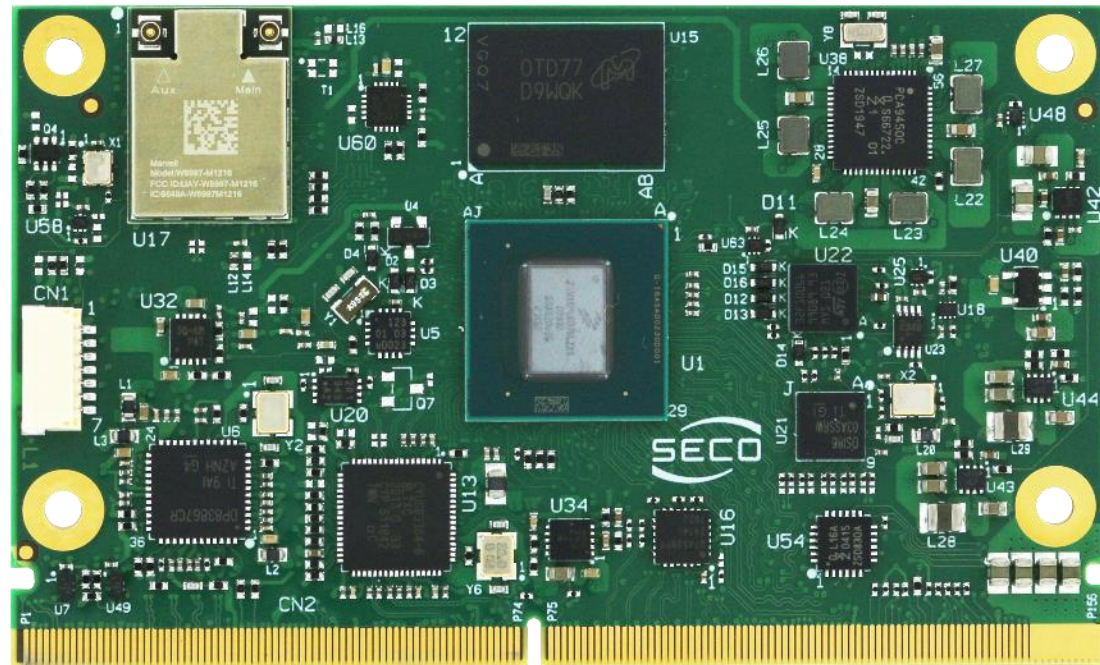

2.1 Introduction

SOM-SMARC-MX8M-PLUS is a SMARC Rel. 2.1 compliant module with NXP i.MX 8M Plus family Applications Processors. Featuring multicore and real-time processing together with neural networks acceleration and a vision system. It is a scalable solution designed by SECO for home automation, transportation, digital signage and vending machines, and applicable to scenarios requiring advanced security, connectivity, multimedia and real-time response.

The module offers a very high level of integration, both for all most common used peripherals in the ARM domain and for bus interfaces typically used in the x86 domain, like PCI-Express

Presented in the SMARC ("Smart Mobility ARChitecture") form factor, offering the computing abilities of a standard board, with the possibilities of combining with a ready-to-use carrier board like the SECO CSM-B79 or customised carrier board.

For external interfacing to standard devices, a carrier board with a 314-pin MXM connector is needed. This board will implement all the routing of the interface signals to external standard connectors, as well as the integration of other peripherals/devices not already included in SOM-SMARC-MX8M-PLUS module.

2.2 Technical Specifications

Processors

NXP i.MX 8M Plus Family:

- Quad - 4x (or Dual - 2x) Cortex®-A53 cores up to 1.8GHz, Cortex®-M7 core up to 800MHz, Full featured
- Quad - 4x Cortex®-A53 cores up to 1.8GHz, Cortex®-M7 core up to 800MHz, without Neural Processing Unit (NPU)
- Quad Lite - 4x Cortex®-A53 cores up to 1.8GHz, Cortex®-M7 core up to 800MHz, without Hardware Video Codec (VPU), Neural Processing Unit (NPU), and Image Sensor Processor (ISP)

Memory

Soldered Down LPDDR4-4000 memory, 32-bit interface, up to 6GB

Graphics

Integrated Graphics Processing Unit GC7000UL

- supports 2 independent displays, OpenGL ES 3.0, Open CL 1.2, Vulkan.

Embedded VPU

- supports H/W decoding of HEVC/H.265, AVC/H.264, VP8, VP9 0.2
- supports H/W encoding of HEVC/H.265, AVC/H.264

Video Interfaces

1 x HDMI

1 x LVDS 18/24-bit Single/Dual Channel (factory option)

1 x eDP (factory alternative to one LVDS channel)

Video Resolution

HDMI, resolution up to 3840x2160 @ 30Hz

LVDS/eDP, resolution up to 1920x1080 @ 60Hz

Mass Storage

eMMC 5.1 Drive soldered on-board, up to 64GB

SD 1-bit/4-bit SDIO 3.0 interface

PCI Express

Up to 1 x PCI-e x1 Gen3 port

Networking

2 x Gigabit Ethernet interface

Optional WiFi 802.11a/b/g/n/ac + BT 5.1 module onboard

USB

1 x USB 2.0 Host or 1 x USB 2.0 Client port

USB 3.0 Hub onboard, makes available

- 2 x USB 2.0 ports
- 2 x USB 3.0 Superspeed ports

Audio

Up to 2 x I2S Audio interface (1 x I2S to BLE module as a factory alternative)

Serial ports

2 x UART Tx/Rx/RTS/CTS

2 x UART Tx/Rx

2 x CAN Bus

Other Interfaces

1 x 4-lanes (limited bandwidth) + 1 x 2-lanes CSI camera interfaces

I2C Bus

SPI interface

QuadSPI interface

14 x GPIOs

Boot select signals

Power Management Signals (Standby not supported)

Power supply voltage: +5V_{DC}

RTC voltage: 3.3V

Operating temperature:

Commercial version 0°C ÷ +60°C **.

Industrial version -40°C ÷ +85°C **.

Dimensions: 50 x 82 mm (1.97" x 3.23")

Supported Operating Systems:

Linux 64-bit



*** Measured at any point of SECO standard heatspreader for this product, during any and all times (including start-up). Actual temperature will widely depend on application, enclosure and/or environment. Upon customer to consider application-specific cooling solutions for the final system to keep the heatspreader temperature in the range indicated. Please also check paragraph 4.2*

2.3 Electrical Specifications

According to SMARC specifications, the SOM-SMARC-MX8M-PLUS module needs to be supplied only with an external +5V_{DC} power supply.

For Real Time Clock working and CMOS memory data retention, it is also needed a backup battery voltage. All these voltages are supplied directly through card edge fingers (see connector's pinout).

All remaining voltages needed for board's working are generated internally from +5V_{DC} power rail.

2.3.1 Power Consumption

SOM-SMARC-MX8M-PLUS module, like all SMARC modules, needs a carrier board for its normal working. All connections with the external world come through this carrier board, which also provides the required voltage to the board.

Measurements of power consumption from VDD_IN power rail (5V_{DC}) that supplies the board are reported here for 3 different board factory configurations.

Status	Processor		
	i.MX 8M Plus Quad 6GB LPDDR4 64GB eMMC	i.MX 8M Plus Quad 4GB LPDDR4 32GB eMMC	i.MX 8M Plus Quad 1GB LPDDR4 4GB eMMC
Video	LVDS	HDMI	eDP
Idle	2.78W	2.59W	2.23W
GPU and CPU working at full load, video reproduction of a 1080p video	4.87W	3.95W	4.52W
As above, with active two GbE and two USB 3.0 ports	6.61W	5.55W	5.72W
RTC Power consumption on VDD_RTC (when VDD_IN off)	300nA		

Please consider that power consumption is strongly dependent on the board's configuration, on number of processor cores active and from the interfaces that are SW enabled.

2.3.2 Power Rails meanings

In all the tables contained in this manual, Power rails are named with the following meaning:

VDD_IN: Module power input voltage. +5V voltage directly coming from the card edge connector.

VDD_RTC: Low current RTC circuit backup power. 3V coin cell voltage coming from the edge card for supplying the RTC clock on the I.MX 8M

_RUN: Switched voltages, i.e. power rails that are active only when the board is in ACPI's S0 (Working) state. Examples: +1.8V_RUN, +3.3V_RUN, +5V_RUN.

_ALW: Always-on voltages, i.e. power rails that are active both in ACPI's S0 (Working), S3 (Standby) and S5 (Soft Off) state. Examples: +5V_ALW, +3.3V_ALW.

2.4 Mechanical Specifications

According to SMARC® specifications, the board dimensions are: 50 x 82 mm (1.97" x 3.23") including the pin numbering and edge finger pattern.

Printed circuit of the board is made of ten layers, some of them are ground planes, for disturbance rejection.

The MXM connector accommodates various connector heights for different carrier board applications needs.

When using different connector heights, please consider that, according to SMARC specifications, components placed on bottom side of the module will have a maximum height of 1.3mm. Keep this value in mind when choosing the MXM connector's height, if there is the need to place components on the carrier board in the zone below the SMARC module.

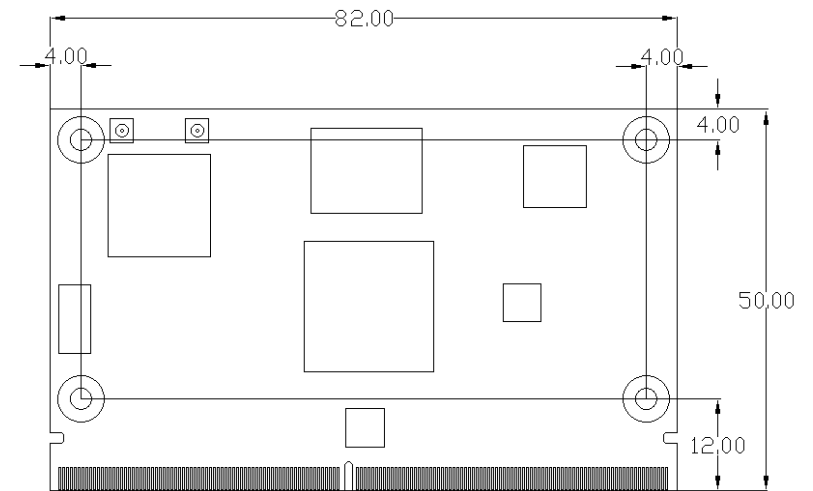

2.5 Supported Operating Systems

SOM-SMARC-MX8M-PLUS module supports the following operating systems:

- Linux

SECO will offer the BSP (Board Support Package) for these O.Ss, to reduce at minimum SW development of the board, supplying all the drivers and libraries needed for use both with the SMARC board and the Carrier Board, assuming that the Carrier Board is designed following SECO SMARC Design Guide, with the same IC's.

For further details, please visit <https://www.seco.com>.

2.6 Block Diagram

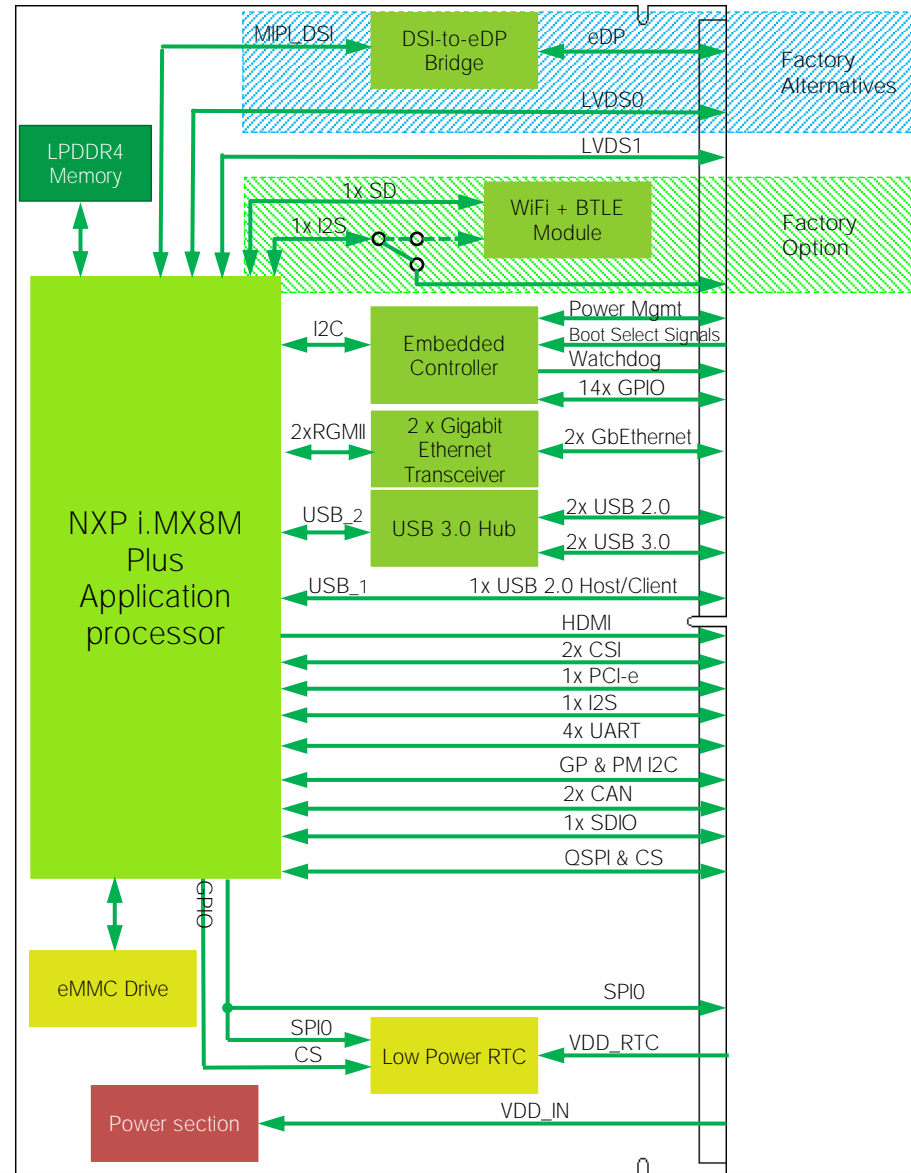

Chapter 3.

CONNECTORS

- Introduction
- Connectors description



3.1 Introduction

According to SMARC specifications, all interfaces to the board are available through a single card edge connector.

TOP SIDE

BOTTOM SIDE



Card edge golden
finger, pin P1

Card edge golden
finger, pin P156



Card edge golden
finger, pin S158

Card edge golden
finger, pin S1

3.2 Connectors description

3.2.1 WiFi/BTLE Module

This SMARC® module can be equipped, by factory option, with a Dual band (2.4GHz + 5.0 GHz) WLAN 802.11 a/b/g/n/ac + BT 5.0 combo embedded module AzureWave p/n AW-CM276NF.

Aux antenna is used for WLAN and BT while main antenna is used for WLAN only. These are type IPEX MHF4 RF connectors.

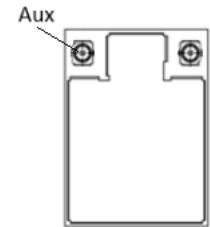

3.2.2 SMARC® Connector

According to SMARC® Rel 2.1 specification, all interface signals are reported on the card edge connector, which is a 314-pin Card Edge that can be inserted into standard low profile 314 pin 0.5mm right pitch angle connector that was originally defined for use with MXM3 graphics cards.

Not all signals contemplated in the SMARC® Rel 2.1 are implemented on card edge connector, therefore, please refer to the following table for a list of effective signals reported on the card edge connector.

Consider that the signals labelled as RSVD are for factory production use only and shall be left unused, otherwise the module may not boot or function properly.

For accurate signals description, please consult the following paragraphs.

SMARC® Golden Finger Connector – CN2							
TOP SIDE				BOTTOM SIDE			
SIGNAL GROUP	Type	Pin name	Pin nr.	Pin nr.	Pin name	Type	SIGNAL GROUP
				S1	I2C_CAM1_CK	O	CAMERA
MANAGEMENT	I	SMB_ALERT_IV8#	P1	S2	I2C_CAM1_DAT	I/O	CAMERA
		GND	P2	S3	GND		
CAMERA	I	CSII_CK+	P3	S4	RSVD		
CAMERA	I	CSII_CK-	P4	S5	I2C_CAM0_CK	O	CAMERA
GBE	I/O	GBE1_SDP	P5	S6	CAM_MCK	O	CAMERA
GBE	I/O	GBE0_SDP	P6	S7	I2C_CAM0_DAT	I/O	CAMERA
CAMERA	I	CSII_RX0+	P7	S8	CSIO_CK+	I	CAMERA
CAMERA	I	CSII_RX0-	P8	S9	CSIO_CK-	I	CAMERA
		GND	P9	S10	GND		
CAMERA	I	CSII_RX1+	P10	S11	CSIO_RX0+	I	CAMERA
CAMERA	I	CSII_RX1-	P11	S12	CSIO_RX0-	I	CAMERA
		GND	P12	S13	GND		
CAMERA	I	CSII_RX2+	P13	S14	CSIO_RX1+	I	CAMERA
CAMERA	I	CSII_RX2-	P14	S15	CSIO_RX1-	I	CAMERA
		GND	P15	S16	GND		

CAMERA	I	CSII_RX3+	P16	S17	GBE1_MDIO+	I/O	GBE
CAMERA	I	CSII_RX3-	P17	S18	GBE1_MDIO-	I/O	GBE
		GND	P18	S19	GBE1_LINK100#	O	GBE
GBE	I/O	GBE0_MDI3-	P19	S20	GBE1_MDII+	I/O	GBE
GBE	I/O	GBE0_MDI3+	P20	S21	GBE1_MDII-	I/O	GBE
GBE	O	GBE0_LINK100#	P21	S22	GBE1_LINK1000#	O	GBE
GBE	O	GBE0_LINK1000#	P22	S23	GBE1_MDI2+	I/O	GBE
GBE	I/O	GBE0_MDI2-	P23	S24	GBE1_MDI2-	I/O	GBE
GBE	I/O	GBE0_MDI2+	P24	S25	GND		
GBE	O	GBE0_LINK_ACT#	P25	S26	GBE1_MDI3+	I/O	GBE
GBE	I/O	GBE0_MDII-	P26	S27	GBE1_MDI3-	I/O	GBE
GBE	I/O	GBE0_MDII+	P27	S28	N.C.		
		N.C.	P28	S29	N.C.		
GBE	I/O	GBE0_MDIO-	P29	S30	N.C.		
GBE	I/O	GBE0_MDIO+	P30	S31	GBE1_LINK_ACT#	O	GBE
SPI_INTERFACE	O	SPIO_CS1#	P31	S32	N.C.		
		GND	P32	S33	N.C.		
SDIO_CARD	I	SDIO_WP	P33	S34	GND		
SDIO_CARD	I/O	SDIO_CMD	P34	S35	USB4+	I/O	USB
SDIO_CARD	I	SDIO_CD#	P35	S36	USB4-	I/O	USB
SDIO_CARD	O	SDIO_CK	P36	S37	N.C.		
SDIO_CARD	O	SDIO_PWR_EN	P37	S38	AUDIO_MCK	O	AUDIO
		GND	P38	S39	I2S0_LRCK	I/O	AUDIO
SDIO_CARD	I/O	SDIO_D0	P39	S40	I2S0_SDOUT	O	AUDIO
SDIO_CARD	I/O	SDIO_D1	P40	S41	I2S0_SDIN	I	AUDIO
SDIO_CARD	I/O	SDIO_D2	P41	S42	I2S0_CK	O	AUDIO
SDIO_CARD	I/O	SDIO_D3	P42	S43	N.C.		
SPI_INTERFACE	O	SPIO_CS0#	P43	S44	N.C.		
SPI_INTERFACE	O	SPIO_CK	P44	S45	N.C.		

SPI_INTERFACE	I	SPIO_DIN	P45	S46	N.C.		
SPI_INTERFACE	O	SPIO_DO	P46	S47	GND		
		GND	P47	S48	I2C_GP_CK	I/O	I2C
		N.C.	P48	S49	I2C_GP_DAT	I/O	I2C
		N.C.	P49	S50	I2S2_LRCK	I/O	AUDIO
		GND	P50	S51	I2S2_SDOUT	O	AUDIO
		N.C.	P51	S52	I2S2_SDIN	I	AUDIO
		N.C.	P52	S53	I2S2_CK	O	AUDIO
		GND	P53	S54	N.C.		
SPI_INTERFACE	O	QSPI_CS0#	P54	S55	USB5_EN_OC#	I/O	USB
SPI_INTERFACE	O	QSPI_CS1#	P55	S56	QSPI_IO_2	I/O	SPI_INTERFACE
SPI_INTERFACE	O	QSPI_CK	P56	S57	QSPI_IO_3	I/O	SPI_INTERFACE
SPI_INTERFACE	I/O	QSPI_IO_1	P57	S58	N.C.		
SPI_INTERFACE	I/O	QSPI_IO_0	P58	S59	N.C.		
		GND	P59	S60	N.C.		
USB	I/O	USB0+	P60	S61	GND		
USB	I/O	USB0-	P61	S62	USB3_SSTX+	O	USB
USB	I/O	USB0_EN_OC#	P62	S63	USB3_SSTX-	O	USB
USB	I	USB0_VBUS_DET	P63	S64	GND		
USB	I	USB0_OTG_ID	P64	S65	USB3_SSRX+	I	USB
USB	I/O	USB1+	P65	S66	USB3_SSRX-	I	USB
USB	I/O	USB1-	P66	S67	GND		
USB	I/O	USB1_EN_OC#	P67	S68	USB3+	I/O	USB
		GND	P68	S69	USB3-	I/O	USB
USB	I/O	USB2+	P69	S70	GND		
USB	I/O	USB2-	P70	S71	USB2_SSTX+	O	USB
USB	I/O	USB2_EN_OC#	P71	S72	USB2_SSTX-	O	USB
		RESERVED	P72	S73	GND		
		N.C	P73	S74	USB2_SSRX+	I	USB

USB	I/O	USB3_EN_OC#	P74	S75	USB2_SSRX-	I	USB
PCI_e	O	PCIE_A_RST#	P75	S76	N.C.		
USB	I/O	USB4_EN_OC#	P76	S77	N.C.		
PCI_e	I/O	PCIE_B_CKREQ#	P77	S78	N.C.		
PCI_e	I/O	PCIE_A_CKREQ#	P78	S79	N.C.		
		GND	P79	S80	GND		
		N.C.	P80	S81	N.C.		
		N.C.	P81	S82	N.C.		
		GND	P82	S83	GND		
PCI_e	O	PCIE_A_REFCK+	P83	S84	N.C.		
PCI_e	O	PCIE_A_REFCK-	P84	S85	N.C.		
		GND	P85	S86	GND		
PCI_e	I	PCIE_A_RX+	P86	S87	N.C.		
PCI_e	I	PCIE_A_RX-	P87	S88	N.C.		
		GND	P88	S89	GND		
PCI_e	O	PCIE_A_TX+	P89	S90	N.C.		
PCI_e	O	PCIE_A_TX-	P90	S91	N.C.		
		GND	P91	S92	GND		
SECONDARY_DISPLAY	O	HDMI_D2+	P92	S93	N.C.		
SECONDARY_DISPLAY	O	HDMI_D2-	P93	S94	N.C.		
		GND	P94	S95	N.C.		
SECONDARY_DISPLAY	O	HDMI_D1+	P95	S96	N.C.		
SECONDARY_DISPLAY	O	HDMI_D1-	P96	S97	N.C.		
		GND	P97	S98	N.C.		
SECONDARY_DISPLAY	O	HDMI_D0+	P98	S99	N.C.		
SECONDARY_DISPLAY	O	HDMI_D0-	P99	S100	N.C.		
		GND	P100	S101	GND		
SECONDARY_DISPLAY	O	HDMI_CK+	P101	S102	N.C.		
SECONDARY_DISPLAY	O	HDMI_CK-	P102	S103	N.C.		

		GND	P103	S104	N.C.		
SECONDARY_DISPLAY	I	HDMI_HPD	P104	S105	N.C.		
SECONDARY_DISPLAY	I/O	HDMI_CTRL_CK	P105	S106	N.C.		
SECONDARY_DISPLAY	I/O	HDMI_CTRL_DAT	P106	S107	LCDI_BKLT_EN	O	LCD_SUPPORT
		N.C.	P107	S108	LVDSI_CK+	O	PRIMARY_DISPLAY
GPIO	I/O	GPIO0 / CAM0_PWR#	P108	S109	LVDSI_CK-	O	PRIMARY_DISPLAY
GPIO	I/O	GPIO1 / CAM1_PWR#	P109	S110	GND		
GPIO	I/O	GPIO2 / CAM0_RST#	P110	S111	LVDSI_0+	O	PRIMARY_DISPLAY
GPIO	I/O	GPIO3 / CAM1_RST#	P111	S112	LVDSI_0-	O	PRIMARY_DISPLAY
GPIO	I/O	GPIO4 / HDA_RST#	P112	S113	N.C.		
GPIO	I/O	GPIO5 / PWM_OUT	P113	S114	LVDSI_1+	O	PRIMARY_DISPLAY
GPIO	I/O	GPIO6 / TACHIN	P114	S115	LVDSI_1-	O	PRIMARY_DISPLAY
GPIO	I/O	GPIO7	P115	S116	LCDI_VDD_EN	O	LCD_SUPPORT
GPIO	I/O	GPIO8	P116	S117	LVDSI_2+	O	PRIMARY_DISPLAY
GPIO	I/O	GPIO9	P117	S118	LVDSI_2-	O	PRIMARY_DISPLAY
GPIO	I/O	GPIO10	P118	S119	GND		
GPIO	I/O	GPIO11	P119	S120	LVDSI_3+	O	PRIMARY_DISPLAY
		GND	P120	S121	LVDSI_3-	O	PRIMARY_DISPLAY
MANAGEMENT	I/O	I2C_PM_CK	P121	S122	LCDI_BKLT_PWM	O	LCD_SUPPORT
MANAGEMENT	I/O	I2C_PM_DAT	P122	S123	GPIO13	I/O	GPIO
BOOT_SEL	I	BOOT_SELO#	P123	S124	GND		
BOOT_SEL	I	BOOT_SEL1#	P124	S125	LVDS0_0+ / eDPO_TX0+	O	PRIMARY_DISPLAY
BOOT_SEL	I	BOOT_SEL2#	P125	S126	LVDS0_0- / eDPO_TX0-	O	PRIMARY_DISPLAY
MANAGEMENT	O	RESET_OUT#	P126	S127	LCD0_BKLT_EN	O	LCD_SUPPORT
MANAGEMENT	I	RESET_IN#	P127	S128	LVDS0_1+ / eDPO_TX1+	O	PRIMARY_DISPLAY
MANAGEMENT	I	POWER_BTN#	P128	S129	LVDS0_1- / eDPO_TX1+	O	PRIMARY_DISPLAY
ASYNC_SERIAL	O	SER0_TX	P129	S130	GND		
ASYNC_SERIAL	I	SER0_RX	P130	S131	LVDS0_2+ / eDPO_TX2+	O	PRIMARY_DISPLAY
ASYNC_SERIAL	O	SER0_RTS#	P131	S132	LVDS0_2- / eDPO_TX2+	O	PRIMARY_DISPLAY

ASYNC_SERIAL	I	SER0_CTS#	P132	SI33	LCD0_VDD_EN	O	LCD_SUPPORT
		GND	P133	SI34	LVDS0_CK+ eDPO_AUX+	/ O	PRIMARY_DISPLAY
ASYNC_SERIAL	O	SER1_TX	P134	SI35	LVDS0_CK- eDPO_AUX+	/ O	PRIMARY_DISPLAY
ASYNC_SERIAL	I	SER1_RX	P135	SI36	GND		
ASYNC_SERIAL	O	SER2_TX	P136	SI37	LVDS0_3+ / eDPO_TX3+	O	PRIMARY_DISPLAY
ASYNC_SERIAL	I	SER2_RX	P137	SI38	LVDS0_3- / eDPO_TX3+	O	PRIMARY_DISPLAY
ASYNC_SERIAL	O	SER2_RTS#	P138	SI39	I2C_LCD_CK	O	LCD_SUPPORT
ASYNC_SERIAL	I	SER2_CTS#	P139	SI40	I2C_LCD_DAT	I/O	LCD_SUPPORT
ASYNC_SERIAL	O	SER3_TX	P140	SI41	LCD0_BKLT_PWM	O	LCD_SUPPORT
ASYNC_SERIAL	I	SER3_RX	P141	SI42	GPIO12	I/O	GPIO
		GND	P142	SI43	GND		
CAN	O	CAN0_TX	P143	SI44	eDPO_HPD	I	PRIMARY_DISPLAY
CAN	I	CAN0_RX	P144	SI45	WDT_TIME_OUT#	O	WATCHDOG
CAN	O	CAN1_TX	P145	SI46	PCIE_WAKE#	I	PCI_e
CAN	I	CAN1_RX	P146	SI47	VDD_RTC		
		VDD_IN	P147	SI48	LID#	I	MANAGEMENT
		VDD_IN	P148	SI49	SLEEP#	I	MANAGEMENT
		VDD_IN	P149	SI50	VIN_PWR_BAD#	I	MANAGEMENT
		VDD_IN	P150	SI51	CHARGING#	I	MANAGEMENT
		VDD_IN	P151	SI52	CHARGER_PRSENT#	I	MANAGEMENT
		VDD_IN	P152	SI53	CARRIER_STBY#	O	MANAGEMENT
		VDD_IN	P153	SI54	CARRIER_PWR_ON	O	MANAGEMENT
		VDD_IN	P154	SI55	FORCE_RECOV#	I	BOOT_SEL
		VDD_IN	P155	SI56	BATLOW#	I	MANAGEMENT
		VDD_IN	P156	SI57	TEST#	I	MANAGEMENT
				SI58	GND		

All schematics (henceforth also referred to as material) contained in this manual are provided by SECO S.p.A. for the sole purpose of supporting the customers' internal development activities.



The schematics are provided "AS IS". SECO makes no representation regarding the suitability of this material for any purpose or activity and disclaims all warranties and conditions with regard to said material, including but not limited to, all expressed or implied warranties and conditions of merchantability, suitability for a specific purpose, title and non-infringement of any third party intellectual property rights. The customer acknowledges and agrees to the conditions set forth that these schematics are provided only as an example and that he will conduct an independent analysis and exercise judgment in the use of any and all material. SECO declines all and any liability for use of this or any other material in the customers' product design

3.2.2.1 LCD Display Support Signals

The panel control signals are:

LCD0_VDD_EN: Panel #0 VDD enable signal. Set high to enable. +1.8V_RUN electrical level Output.

LCD0_BKLT_EN: Panel #0 Backlight Enable signal. It can be used to turn On/Off the backlight's lamps of a connected LVDS display. +1.8V_RUN electrical level Output

LCD0_BKLT_PWM: This signal can be used to adjust the Panel #0 backlight brightness in displays supporting Pulse Width Modulated (PWM) regulations. +1.8V_RUN electrical level Output

LCD1_VDD_EN: Panel #1 VDD enable signal. Set high to enable. +1.8V_RUN electrical level Output

LCD1_BKLT_EN: Panel #1 Backlight Enable signal. It can be used to turn On/Off the backlight's lamps of a connected LVDS display. +1.8V_RUN electrical level Output.

LCD1_BKLT_PWM: This signal can be used to adjust the Panel #1 backlight brightness in displays supporting Pulse Width Modulated (PWM) regulations. +1.8V_RUN electrical level Output.

I2C LCD signals are managed by SoC I2C2 bus.

I2C_LCD_DAT: LCD I2C Data. This signal is used to read the LCD display EDID EEPROM. +1.8V_RUN electrical level Bidirectional with a 2k2Ω pull-up resistor.

I2C_LCD_CLK: LCD I2C Clock: This signal is used to read the LCD display EDID EEPROM. +1.8V_RUN electrical level Output with a 2k2Ω pull-up resistor.

On this bus a selection of addresses must be left reserved for on-board peripherals as presented in this table (also consider that this bus is shared with CAM0 from par. 3.2.2.4):

I2C2 Bus	
Address	Peripheral
0x2D	DSI Bridge
0x25	USB Hub

Please refer to the following schematics as an example of connection of LCD display control signals and supply voltage selection jumpers.

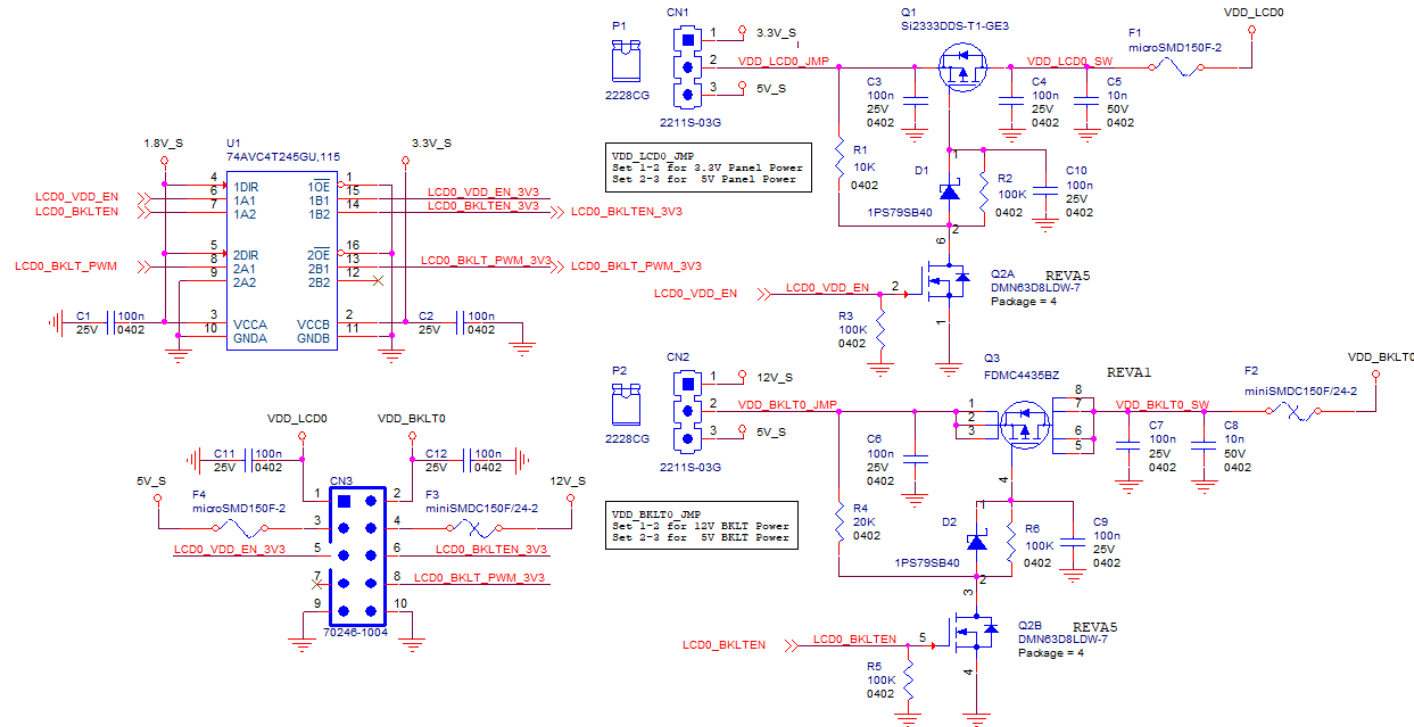

3.2.2.2 eDP / Dual Channel LVDS (factory alternatives)

A dual channel LVDS interface is natively supported by the SOC, with a maximum supported resolution of 1920x1200 @ 60Hz, while an eDP interface can be selected as a factory alternative to be present on the edge pinout in place of Channel #0 of the LVDS interface.

ONLY ONE set of signals from the following two sets are present, dependent on the factory board configuration.

EITHER the signals for Channel #0 are LVDS:

LVDS0_0+/LVDS0_0-: LVDS Channel #0 differential data pair #0.

LVDS0_1+/LVDS0_1-: LVDS Channel #0 differential data pair #1.

LVDS0_2+/LVDS0_2-: LVDS Channel #0 differential data pair #2.
 LVDS0_3+/LVDS0_3-: LVDS Channel #0 differential data pair #3.
 LVDS0_CK+/LVDS0_CK-: LVDS Channel #0 differential Clock.

OR the signals for Channel #0 are eDP:

eDPO_TX0+/ eDPO_TX0-: eDP Channel #0 differential data pair #0.
 eDPO_TX1+/ eDPO_TX1-: eDP Channel #0 differential data pair #1.
 eDPO_TX2+/ eDPO_TX2-: eDP Channel #0 differential data pair #2.
 eDPO_TX3+/ eDPO_TX3-: eDP Channel #0 differential data pair #3.
 eDPO_AUX+/ eDPO_AUX-: eDP Channel #0 differential Clock.

eDPO_HPD: Hot Plug Detect, Active high Input signal of +1.8V_RUN electrical level from carrier board. 1MΩ pull-down resistor is placed on module for this signal.

Please refer to the following schematics as an example of connection of eDP interface on the carrier board. Hot Plug Detect signal must be buffered to

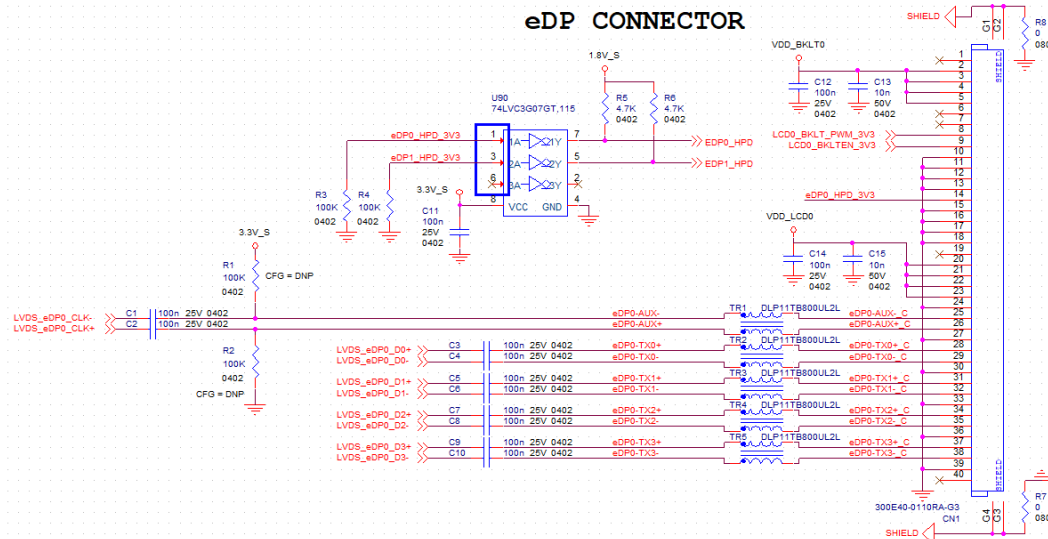

prevent back feeding of power from the display to the module as well as level translation.

The signals for Channel #1 of the LVDS interface is always available on the edge pinout regardless of the factory board configuration.

LVDSI_1+ / LVDSI_0- : LVDS Channel #1 differential data pair #0

LVDSI_1+ / LVDSI_1-: LVDS Channel #1 differential data pair #1

LVDSI_2+ / LVDSI_2-: LVDS Channel #1 differential data pair #2

LVDSI_3+ / LVDSI_3-: LVDS Channel #1 differential data pair #3

LVDSI_CLK+ / LVDSI_CLK-: LVDS Channel #1 differential Clock

Please refer to the following schematics as an example of connection of dual channel LVDS interface on the carrier board, with EMI filtering section included.

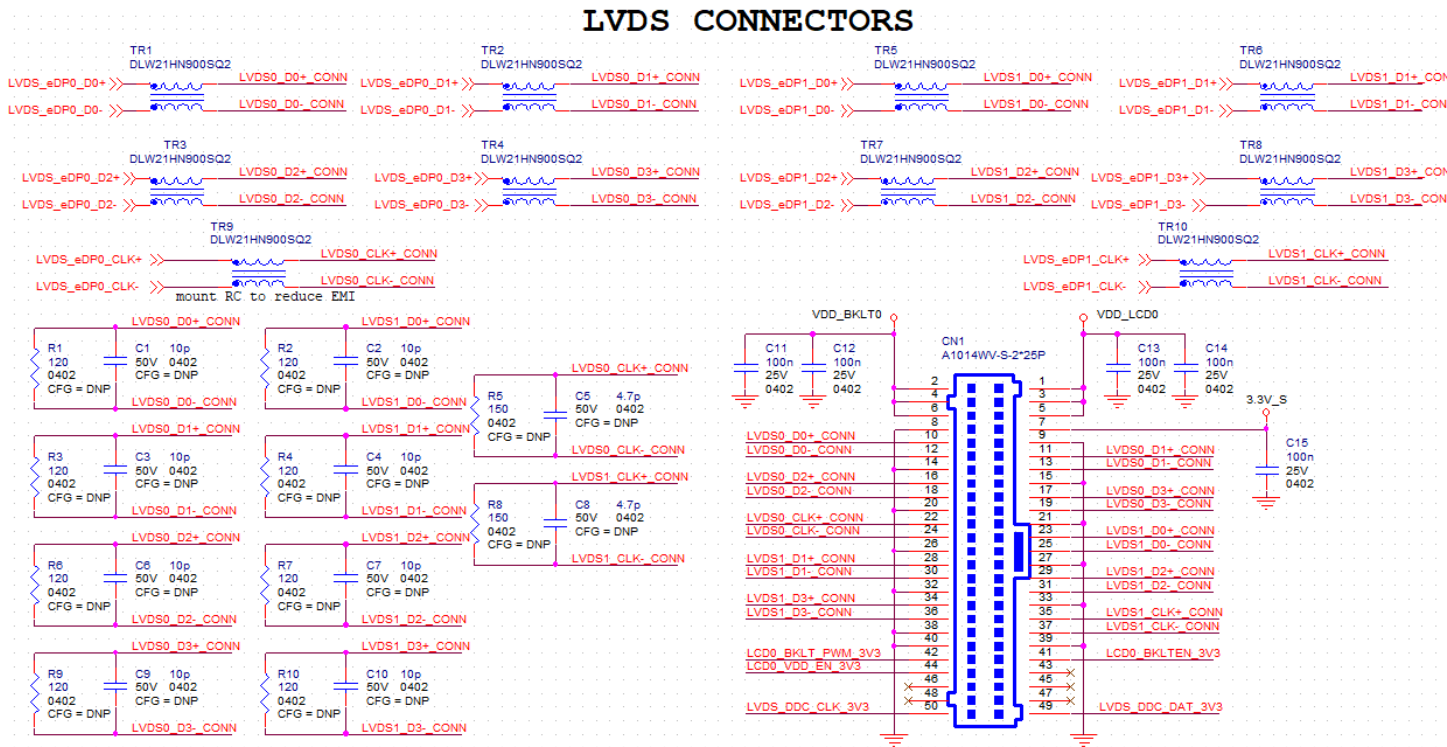

3.2.2.3 Secondary Display (HDMI interface) signals

The NXP i.MX 8M processor has an HD Display Transmitter Controller (HDMI TX), which provides a HDMI interface with resolution limited by the NXP SoC up to 3840x2160 @ 30Hz.

The signals are:

HDMI_D0+/HDMI_D0-: HDMI Output Differential Pair #0

HDMI_D1+/HDMI_D1-: HDMI Output Differential Pair #1

HDMI_D2+/HDMI_D2-: HDMI Output Differential Pair #2

HDMI_CK+/HDMI_CK-: HDMI Differential Clock

HDMI_HPD: Hot Plug Detect Input signal. +1.8V_RUN electrical level signal

HDMI_CTRL_CK: DDC Clock line for HDMI panel. Bidirectional signal, +1.8V_RUN electrical level with a 100kΩ pull-up resistor

HDMI_CTRL_DAT: DDC Data line for HDMI panel. Bidirectional signal, +1.8V_RUN electrical level with a 100kΩ pull-up resistor

Since HDMI Tx module is embedded in the i.MX 8M processors it is not necessary to implement voltage level shifter for TMDS differential pairs on the Carrier board. It is still necessary, however, to implement voltage level shifters on Control data/Clock signals, as well as for Hot Plug Detect signal.

3.2.2.4 Serial Cameras

There are two MIPI-CSI2 interfaces available. The CSI0 interface supports two lanes, the CSI1 interface supports 4 lanes with limited bandwidth. Consider that from the SoC the CSI0 interface is managed by the MIPI_CSI1 group signals and I2C2 bus, while CSI1 is managed by MIPI_CSI2 group signals and I2C3 bus.

CSI0_CK+/CSI0_CK-: 2-lane CSI Input Clock Differential Pair

CSI0_RX0+/CSI0_RX0-: 2-lane CSI Input Differential Pair 0

CSI0_RX1+/CSI0_RX1-: 2-lane CSI Input Differential Pair 1

CSI1_CK+/CSI1_CK-: 4-lane CSI Input Clock Differential Pair

CSI1_RX0+/CSI1_RX0-: 4-lane CSI Input Differential Pair 0

CSI1_RX1+/CSI1_RX1-: 4-lane CSI Input Differential Pair 1

CSI1_RX2+/CSI1_RX2-: 4-lane CSI Input Differential Pair 2

CSI1_RX3+/CSI1_RX3-: 4-lane CSI Input Differential Pair 3

CAM_MCK: Master clock Output for CSI Port #0 and/or #1 support, electrical level 1.8V_RUN

I2C_CAM0_CK: CSI Port #0 dedicated I2C Bus Clock signal, Bi-Directional, electrical level +1.8V_RUN with a 2k2Ω pull-up resistor.

I2C_CAM0_DAT: CSI Port #0 dedicated I2C Bus Data signal, Bi-Directional, electrical level +1.8V_RUN with a 2k2Ω pull-up resistor.

On this bus a selection of addresses must be left reserved for on-board peripherals as presented in this table (also consider that this bus is shared with LCD signals from par. 3.2.2.1):

I2C2 Bus	
Address	Peripheral
0x2D	DSI Bridge
0x25	USB Hub

I2C_CAM1_CK: CSI Port #1 dedicated I2C Bus Clock signal, Bi-Directional, electrical level +1.8V_RUN with a 2k2Ω pull-up resistor.

I2C_CAM1_DAT: CSI Port #1 dedicated I2C Bus Data signal, Bi-Directional, electrical level +1.8V_RUN with a 2k2Ω pull-up resistor.

On this bus a selection of addresses must be left reserved for on-board peripherals as presented in this table:

I2C3 Bus	
Address	Peripheral
0x68	PCIe Clock Generator
0x20	I/O Expander

3.2.2.5 SDI/O interface signals

The NXP i.MX 8M Plus processors offer many different SDIO interfaces, that can be used independently one from the other to implement different mass storages (internal eMMC, internal SD Card, external SDI/O interface).

The SDIO3 signals of the processor are used for the onboard eMMC storage of the module.

The SDIO1 signals of the processor are used for the factory optional onboard WiFi/BTLE module.

The SDIO2 interface of the processor is externally accessible through the edge connector of the module. Supporting 4-bit mode as per the SMARC specification.

The uSDHC controller complies with:

- SD Host Controller Standard Specification version 3.0 with SDR104 signaling to support up to 104MB/sec.
- MMC System Specification version 5.0

The edge accessible SDIO2 signals are as follows:

SDIO_WP: Write Protect bidirectional signal, electrical level +1.8V_RUN (SDR104) or +3.3V_RUN with 10kΩ pull-up resistor. It is used to communicate the status of Write Protect switch on external SD/MMC card.

SDIO_CMD: Command/Response line. Used to send command from Host (i.MX 8M processor) to the connected card, and to send the response from the card to the Host.

SDIO_CD#: Card Detect Input. Active Low Signal, electrical level +1.8V_RUN (SDR104) or +3.3V_RUN with 10kΩ pull-up resistor. This signal must be externally pulled low to signal that a SDIO/MMC Card is present.

SDIO_CK: Clock Line (output), up to 200MHz maximum frequency for SDR104 Mode (4-bit only).

SDIO_PWR_EN: SDIO Power Enable output, active high signal, electrical level +1.8V_RUN (SDR104) or +3.3V_RUN with 2.2kΩ pull-up resistor. It is used to enable the power line supplying SD/SDIO/MMC devices.

SDIO_[D0÷D3]: SDIO data bus. Signals for 4-bit SD/SDIO/MMC communication mode.

Please refer to the following schematics as an example of connection of SDIO interface on the carrier board, with Voltage clamping diodes highly recommended on all signal lines for ESD suppression.

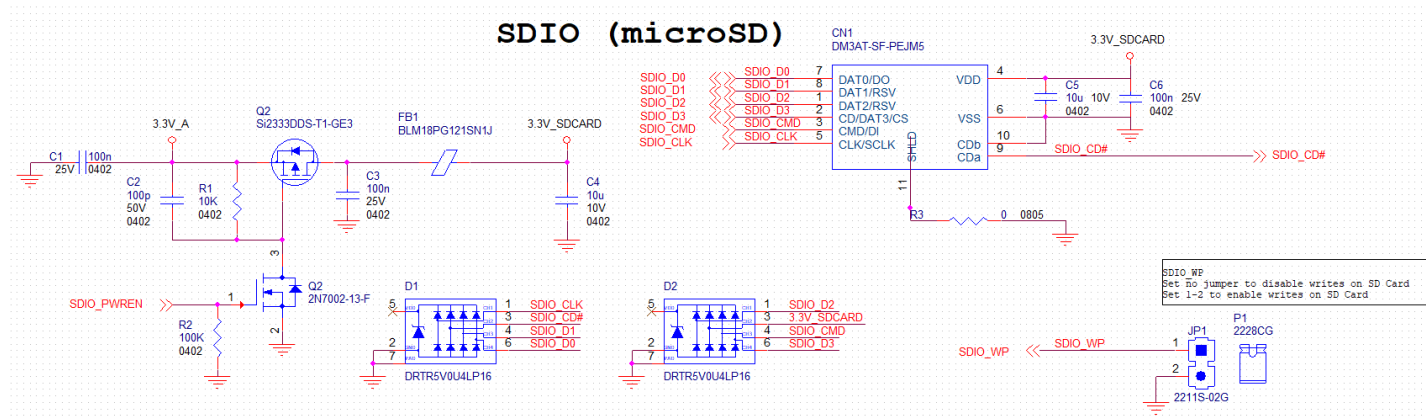

3.2.2.6 SPI interface signals

The signals related to SPI0 are as follows:

SPI0_CS0#: SPI primary Chip select, active low output signal. Electrical level +1.8V_RUN

SPI0_CS1#: SPI secondary Chip select, active low output signal. Electrical level +1.8V_RUN. This signal must be used only in case there are two SPI devices on the carrier board, and the first chip select signal (SPI_CS0#) has already been used. It must not be used in case there is only one SPI device

SPI0_CK: SPI Clock Output to carrier board's SPI embedded devices. Electrical level +1.8V_RUN

SPI0_DIN: SPI0 Master Data Input, electrical level +1.8V_RUN. Input to i.MX 8M from SPI devices embedded on the Carrier Board.

SPI0_DO: SPI0 Master Data Output, electrical level +1.8V_RUN. Output from i.MX 8M to SPI devices embedded on the Carrier Board

The signals related to QuadSPI are as follows:

QSPI_CS0#: QuadSPI primary Chip select, active low output signal. Electrical level +1.8V_RUN.

QSPI_CS1#: QuadSPI secondary Chip select, active low output signal. Electrical level +1.8V_RUN.

QSPI_CK: QuadSPI Master Clock Output. Electrical level +1.8V_RUN. The reference timing signal for all the serial input and output operations

QSPI_IO_[0:3]: QuadSPI Master Data Bidirectional . Electrical level +1.8V_RUN. Data transfer between the master and slaves. In Single I/O mode, QSPI_IO_0 is the QSPI master output/QSPI slave input (MOSI) whereas QSPI_IO_1 is the QSPI master input/QSPI slave output (MISO).

SPI interface can support speed up to 20MHz.

3.2.2.7 Audio interface signals

Here are following the signals related to I2S Audio interfaces:

The first I2S interface managed by the SAI2 group of signals of the SoC is always available on the edge pinout:

AUDIO_MCK: Master clock output to Audio codec. Output from the module to the Carrier board, electrical level +1.8V_RUN

I2S0_LRCK: Left& Right audio synchronization clock. Bi-Directional between the module to the Carrier board, electrical level +1.8V_RUN

I2S0_SDOU: Digital audio Output. Output from the module to the Carrier board, electrical level +1.8V_RUN

I2S0_SDI: Digital audio Input. Input from the module to the Carrier board, electrical level +1.8V_RUN

I2S0_CK: Digital audio clock. Bi-Directional between the module to the Carrier board, electrical level +1.8V_RUN

A second I2S interface managed by the SAI3 group of signals of the SoC is available by default on the edge pinout; as a factory alternative can be routed to the BTLE module to support Bluetooth Audio.

I2S2_LRCK: Left& Right audio synchronization clock. Bi-Directional between the module to the Carrier board, electrical level +1.8V_RUN

I2S2_SDOU: Digital audio Output. Output from the module to the Carrier board, electrical level +1.8V_RUN

I2S2_SDI: Digital audio Input. Input from the module to the Carrier board, electrical level +1.8V_RUN

I2S2_CK: Digital audio clock. Bi-Directional between the module to the Carrier board, electrical level +1.8V_RUN

Signals routed to the Carrier Board have to be connected to I2S Audio Codecs. Please refer to the chosen Codec's Reference Design Guide for correct implementation of audio section on the carrier board.

3.2.2.8 I2C Interface

I2C General Purpose signals are managed by SoC I2C5 bus.

I2C_GP_CK: I2C General Purpose clock signal. Bi-Directional between the module to the Carrier board, electrical level +1.8V_RUN with a 2k2Ω pull-up resistor

I2C_GP_DAT: I2C General Purpose data signal. Bi-Directional between the module to the Carrier board, electrical level +1.8V_RUN with a 2k2Ω pull-up resistor

On this bus a selection of addresses must be left reserved for on-board peripherals as presented in this table:

I2C5 Bus	
Address	Peripheral
0x50	EEPROM

I2C Power Management signals are managed by SoC I2C1 bus.

I2C_PM_CK: Power management clock signal. Bi-Directional between the module to the Carrier board, electrical level +1.8V_ALW with 2.2kΩ pull-up resistor.

I2C_PM_DAT: Power management data signal. Bi-Directional between the module to the Carrier board, electrical level +1.8V_ALW with 2.2kΩ pull-up resistor

On this bus a selection of addresses must be left reserved for on-board peripherals as presented in this table:

I2C1 Bus	
Address	Peripheral
0x40	Embedded Controller
0x25	PMIC
0x48	Secure Element

3.2.2.9 Asynchronous Serial Ports (UART) interface signals

All UART interface signals are directly managed by the i.MX 8M Plus processor. In all versions, the edge connector offers the four following UART interfaces.

SER0_TX: UART #2 Interface, Serial data Transmit (output) line, +1.8V_RUN electrical level

SER0_RX: UART #2 Interface, Serial data Receive (input) line, +1.8V_RUN electrical level with a 100k Ω pull-up resistor

SER0_RTS#: UART #2 Interface, Handshake signal, Request to Send (output) line, +1.8V_RUN electrical level

SER0_CTS#: UART #2 Interface, Handshake signal, Clear to Send (Input) line, +1.8V_RUN electrical level with a 100k Ω pull-up resistor

SER1_TX: UART #4 Interface, Serial data Transmit (output) line, +1.8V_RUN electrical level

SER1_RX: UART #4 Interface, Serial data Receive (input) line, +1.8V_RUN electrical level with a 100k Ω pull-up resistor

SER2_TX: UART #3 Interface, Serial data Transmit (output) line, +1.8V_RUN electrical level

SER2_RX: UART #3 Interface, Serial data Receive (input) line, +1.8V_RUN electrical level with a 100k Ω pull-up resistor

SER2_RTS#: UART #3 Interface, Handshake signal, Request to Send (output) line, +1.8V_RUN electrical level

SER2_CTS#: UART #3 Interface, Handshake signal, Clear to Send (Input) line, +1.8V_RUN electrical level with a 100k Ω pull-up resistor.

SER3_RX: UART #1 Interface, Serial data Receive (input) line, +1.8V_RUN electrical level with a 100k Ω pull-up resistor

SER3_TX: UART #1 Interface, Serial data Transmit (output) line, +1.8V_RUN electrical level

Please consider that interface is at +1.8V_RUN electrical level; therefore, please evaluate well the typical scenario of application. If there isn't any explicit need of interfacing directly at +1.8V_RUN level, for connection to standard serial ports commonly available (like those offered by common PCs, for example) it is mandatory to include an RS-232 transceiver on the carrier board.

In the following schematic here is an example of UART interface on the carrier board, with a multiprotocol transceiver allowing to support RS485/RS-422/RS-232 serial interfaces.

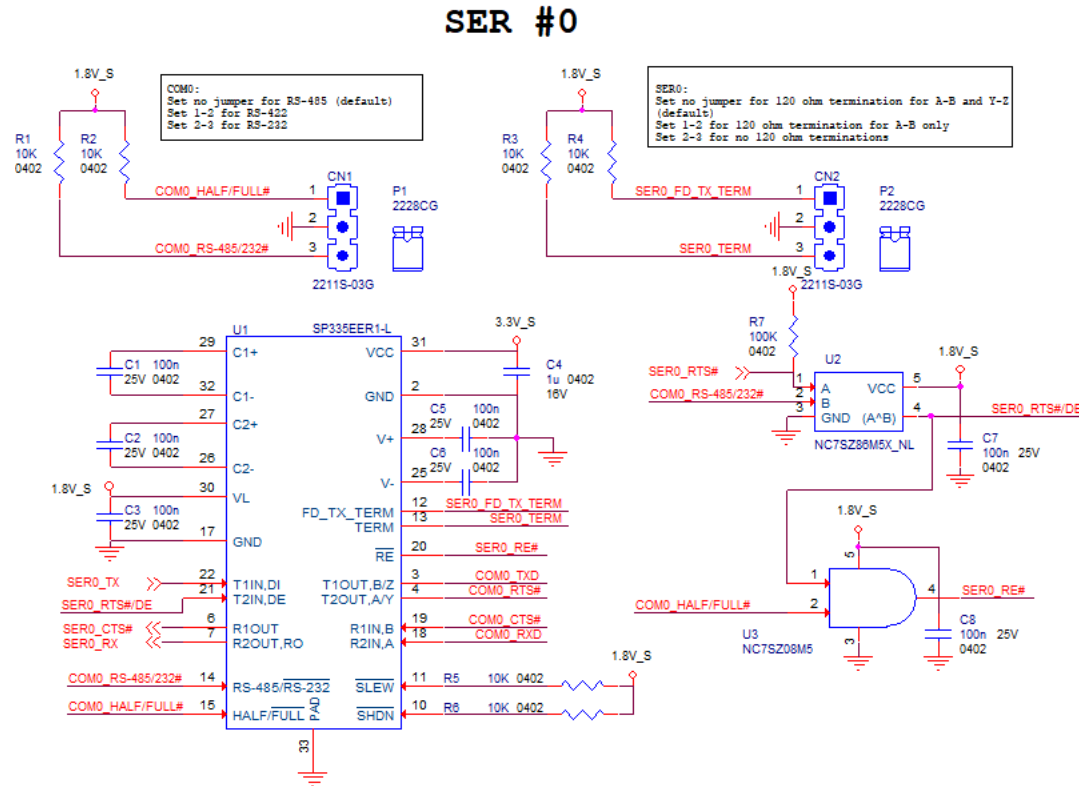

3.2.2.10 USB interface signals

The module has 5x USB ports consisting of 1x USB 2.0 port from the NXP i.MX 8M Plus processor USB 2.0 controller which can be configured at kernel compile time to work as Host or Client, 2x USB 3.0 Superspeed and 2x USB 2.0 from a Cypress USB3304-68LTXC USB 3.0 hub controller.

Here following the signals related to USB interfaces.

USB0+/ USB0-: Universal Serial Bus 2.0 Port #0 differential pair (directly managed by i.MX 8M USB Host Controller core #1).

USB0_EN_OC#: Power Enable and over current monitoring function. Active Low Output signal, +3.3V_ALW electrical level with a 10kΩ pull-up resistor. Refer to SMARC® 2.1 Specification for over current operation information.

The USB0 port is directly managed by i.MX 8M Plus USB Host Controller core #1 and can be used for serial download driving FORCE_RECOV# low. Please take note that the OTG functionality on this port is not supported at runtime, USB0 must be set to work as Client or Host at kernel compile time.

USB1+/ USB1-: Universal Serial Bus Port 2.0 #1 differential pair.

USB1_EN_OC#: Power Enable and over current monitoring function. Active Low Output signal, +3.3V_ALW electrical level with a 10kΩ pull-up resistor. Refer to SMARC® 2.1 Specification for OC operation information.

USB2+/USB2-: Universal Serial Bus Port 2.0 #2 differential pair.

USB2_EN_OC#: Power Enable and over current monitoring function. Active Low Output signal, +3.3V_ALW electrical level with a 10kΩ pull-up resistor. Refer to SMARC® 2.1 Specification for OC operation information.

USB3+/USB3-: Universal Serial Bus Port 2.0 #3 differential pair.

USB3_EN_OC#: Power Enable and over current monitoring function. Active Low Output signal, +3.3V_ALW electrical level with a 10kΩ pull-up resistor. Refer to SMARC® 2.1 Specification for OC operation information.

USB4+/USB4-: Universal Serial Bus Port 2.0 #4 differential pair.

USB4_EN_OC#: Power Enable and over current monitoring function. Active Low Output signal, +3.3V_ALW electrical level with a 10kΩ pull-up resistor. Refer to SMARC® 2.1 Specification for OC operation information.

USB5_EN_OC#: not managed. Tied to GND through a 10kΩ pull-down resistor

USB2_SSTX+/ USB2_SSTX-: USB 3.0 Port #1 Superspeed Transmit differential pair.

USB2_SSRX+/ USB2_SSRX-: USB 3.0 Port #1 Superspeed Receive differential pair.

USB3_SSTX+/ USB3_SSTX-: USB 3.0 Port #2 Superspeed Transmit differential pair.

USB3_SSRX+/ USB3_SSRX-: USB 3.0 Port #2 Superspeed Receive differential pair.

For EMI/ESD protection, common mode chokes on USB data lines, and clamping diodes on USB data and voltage lines, are also needed. Switch with settable current limit on power lines are recommended.

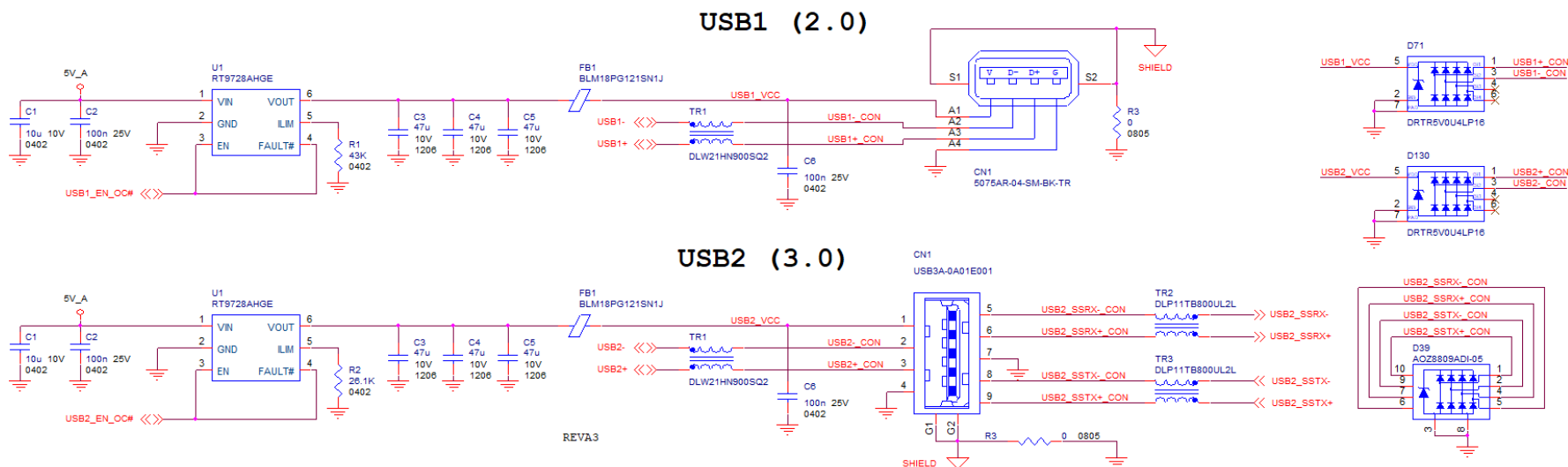

3.2.2.11 PCI Express interface signals

The module can offer one PCI Express x1 lanes, which is directly managed by i.MX 8M Plus processor (PCI express Gen 3.0 is supported).

Here following the signals involved in PCI express management

PCIE_A_RX+/ PCIE_A_RX-: PCI Express lane #0, Transmitting Output Differential pair

PCIE_A_TX+/ PCIE_A_TX-: PCI Express lane #0, Receiving Input Differential pair

PCIE_A_REFCK+/ PCIE_A_REFCK-: PCI Express Reference Clock for lane #0, Differential Pair

PCIE_A_RST#: Reset Signal that is sent from SMARC® Module to a PCI-e device available on the carrier board. Active Low, +3.3V_RUN electrical level.

PCIE_A_CKREQ#: PCIe Port A clock request, can be used for power saving mode on PCIe. Active low, driven by open drain circuitry on the carrier board.

PCIE_WAKE#: PCIe wake up interrupt to host input signal. Active low, +3.3V_ALW electrical level.

3.2.2.12 Gigabit Ethernet signals

Gigabit Ethernet interfaces are realized on the module using two Texas Instruments DP83867CRRGZR Gigabit Ethernet transceivers, which are interfaced to NXP i.MX 8M Plus processor through RGMII interface.

Here following the signals involved in Gigabit Ethernet #0 management:

GBE0_MDI0+/GBE0_MDI0-: Media Dependent Interface (MDI) Transmit/Receive differential pair

GBE0_MDII+/GBE0_MDII-: Media Dependent Interface (MDI) Transmit differential pair

GBE0_MDI2+/GBE0_MDI2-: Media Dependent Interface (MDI) Transmit differential pair

GBE0_MDI3+/GBE0_MDI3-: Media Dependent Interface (MDI) Transmit differential pair

GBE0_LINK_ACT#: Ethernet controller activity indicator. Active Low Output signal, +3.3V_ALW electrical level

GBE0_LINK100#: Ethernet controller 100Mbps link indicator. Active Low Output signal, +3.3V_ALW electrical level

GBE0_LINK1000#: Ethernet controller 1Gbps link indicator. Active Low Output signal, +3.3V_ALW electrical level

GBE0_SDP: Software defined pin, directly managed by TI Gigabit Ethernet PHY transceiver #0. Bidirectional signal, +3.3V_ALW electrical level.

Here following the signals involved in Gigabit Ethernet #1 management:

GBE1_MDI0+/GBE1_MDI0-: Media Dependent Interface (MDI) Transmit/Receive differential pair

GBE1_MDII+/GBE1_MDII-: Media Dependent Interface (MDI) Transmit differential pair

GBE1_MDI2+/GBE1_MDI2-: Media Dependent Interface (MDI) Transmit differential pair

GBE1_MDI3+/GBE1_MDI3-: Media Dependent Interface (MDI) Transmit differential pair

GBE1_LINK_ACT#: Ethernet controller activity indicator. Active Low Output signal, +3.3V_ALW electrical level

GBE1_LINK100#: Ethernet controller 100Mbps link indicator. Active Low Output signal, +3.3V_ALW electrical level

GBE1_LINK1000#: Ethernet controller 1Gbps link indicator. Active Low Output signal, +3.3V_ALW electrical level

GBE1_SDP: Software defined pin, directly managed by TI Gigabit Ethernet PHY transceiver #1. Bidirectional signal, +3.3V_ALW electrical level.

Please refer to the following schematics as an example of connection of Ethernet interface on the carrier board, with TVS diodes specifically designed to protect sensitive components which are connected to high-speed data and transmission lines from overvoltage caused by ESD. In this example, it is also present GBE_CTREF signal connected on pin #2 of the RJ-45 connector. TI Gigabit Ethernet PHY transceiver, however, doesn't need the analog powered centre tap, therefore the signal GBE_CTREF is not available on SMARC® connector.

Please notice that if just a FastEthernet (i.e. 10/100 Mbps) is needed, then only MDI0 and MDI1 differential lanes are necessary, for both Gigabit Ethernet interfaces

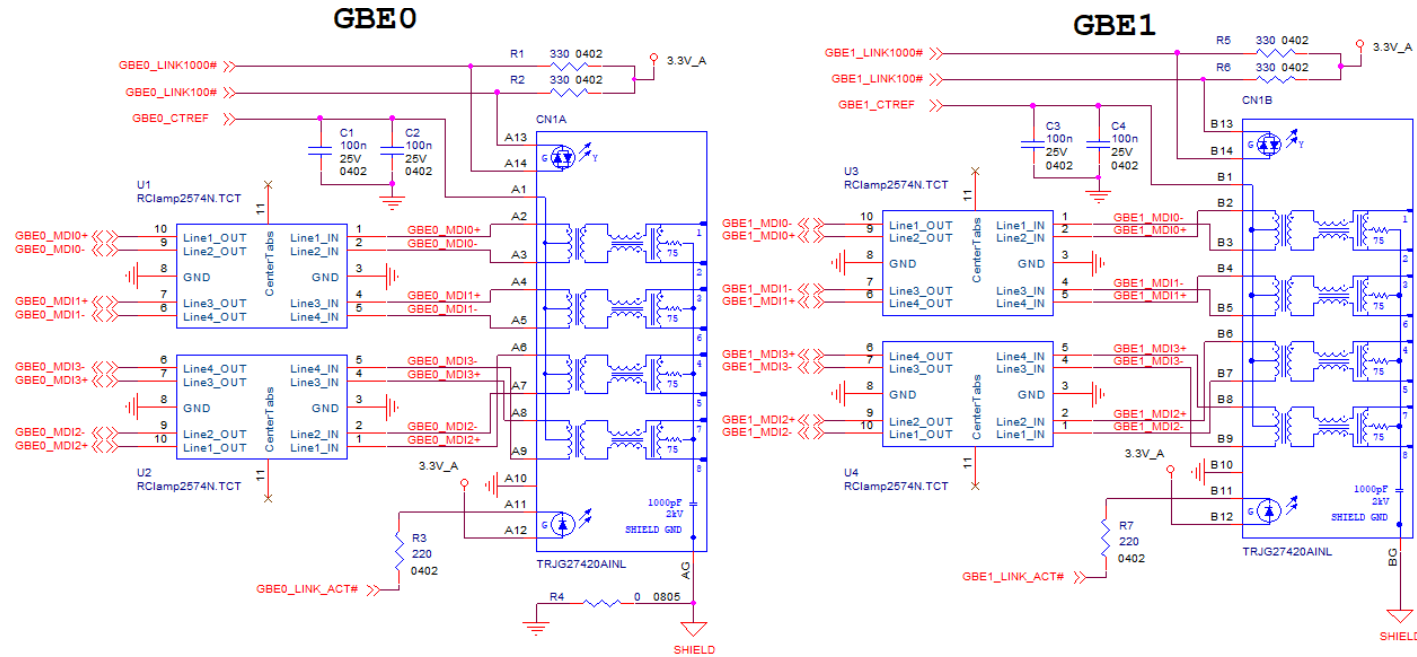

3.2.2.13 CAN interface signals

Two available CAN interface signals are directly managed by the i.MX 8M Plus processor.

CANO_TX: CAN Transmit Output for CAN Bus Channel 0. +1.8V_RUN electrical voltage level signal with a 2k2Ω pull-up resistor

CANO_RX: CAN Receive Input for CAN Bus Channel 0. +1.8V_RUN electrical voltage level signal with a 2k2Ω pull-up resistor

CANI_TX: CAN Transmit Output for CAN Bus Channel 1. +1.8V_RUN electrical voltage level signal with a 2k2Ω pull-up resistor

CANI_RX: CAN Receive Input for CAN Bus Channel 1. +1.8V_RUN electrical voltage level signal with a 2k2Ω pull-up resistor

Please consider that it is not possible to connect the SMARC® CAN interface to any CAN Bus directly, it is necessary to integrate a CAN Bus Transceiver in the Carrier board.

3.2.2.14 Watchdog

WDT_TIME_OUT#: Watchdog timer Output. +1.8V_RUN electrical level

3.2.2.15 Miscellaneous signals

GPIO0 / CAM0_PWR#: General Purpose I/O #0, +1.8V_RUN electrical level

GPIO1 / CAM1_PWR#: General Purpose I/O #1, +1.8V_RUN electrical level

GPIO2 / CAM0_RST#: General Purpose I/O #2, +1.8V_RUN electrical level

GPIO3 / CAM1_RST#: General Purpose I/O #3, +1.8V_RUN electrical level

GPIO4 / HDA_RST#: General Purpose I/O #4, +1.8V_RUN electrical level

GPIO5 / PWM_OUT: General Purpose I/O #5, +1.8V_RUN electrical level

GPIO6 / TACHIN: General Purpose I/O #6, +1.8V_RUN electrical level

GPIO7: General Purpose I/O #7, +1.8V_RUN electrical level

GPIO8: General Purpose I/O #8, +1.8V_RUN electrical level

GPIO9: General Purpose I/O #9, +1.8V_RUN electrical level

GPIO10: General Purpose I/O #10, +1.8V_RUN electrical level

GPIO11: General Purpose I/O #11, +1.8V_RUN electrical level

GPIO12: General Purpose I/O #12, +1.8V_RUN electrical level

GPIO13: General Purpose I/O #13, +1.8V_RUN electrical level

3.2.2.16 Management pins

According to the SMARC® specifications, the input pins listed below are all Active Low, meant to be driven by open drain devices on the carrier board:

VIN_PWR_BAD#: Power Bad indication signal from the Carrier Board

CARRIER_PWR_ON: Power On. Command to the Carrier Board. Output, +1.8V_ALW electrical level

CARRIER_STBY#: Stand By command to the Carrier Board. Output, +1.8V_ALW electrical level

RESET_OUT#: General Purpose Reset. Output, +1.8V_ALW electrical level

RESET_IN#: General Purpose Reset. Input, +3.3V_ALW electrical level

POWER_BTN#: Power Button. Input, +3.3V_ALW electrical level

SLEEP#: Sleep indicator from Carrier board. Input, +3.3V_ALW electrical level (Standby not supported)

LID#: LID Switch. Input, +3.3V_ALW electrical level

BATLOW#: Battery Low indication signal from the Carrier Board. Input, +3.3V_ALW electrical level

CHARGING#: Battery Charging Input Signal from the Carrier Board. Input, +3.3V_ALW electrical level

CHARGER_PRSENT#: Battery Charger Present input from the Carrier Board. Input, +3.3V_ALW electrical level

TEST#: Held low by Carrier to invoke Module vendor specific test function(s). Input, +3.3V_ALW electrical level with a 10k Ω pull-up resistor
SMB_ALERT_IV8#: SM Bus Alert# (interrupt) signal. Input, +1.8V_ALW electrical level with a 2k2 Ω pull-up resistor

3.2.2.17 Boot Select

The following signals are active low and driven by open drain circuitry on the carrier board.

BOOT_SEL0#: Boot Device Selection #0. Input, +1.8V_ALW electrical level with a 10k Ω pull-up resistor

BOOT_SEL1#: Boot Device Selection #1. Input, +1.8V_ALW electrical level with a 10k Ω pull-up resistor

BOOT_SEL2#: Boot Device Selection #2. Input, +1.8V_ALW electrical level with a 10k Ω pull-up resistor

FORCE_RECOV#: Force recovery Mode. Input, +1.8V_ALW electrical level with a 10k Ω pull-up resistor

Chapter 4. Appendices

- Thermal Design



4.1 SoC to Connector Pinout

Some of the signals available on the SMARC® Edge Connector can be reprogrammed to implement different functionalities, according to the i.MX 8M pin-multiplexing possibilities.

In this table is presented the list of connector signals which are connected to the SoC with the corresponding SoC pad and name. Consult the i.MX 8M documentation for the multiplexing capabilities of the listed pads.

SMARC® Golden Finger Connector – CN2							
TOP SIDE				BOTTOM SIDE			
SoC signal	SoC pad	Pin name	Pin nr.	Pin nr.	Pin name	SoC pad	SoC signal
				S1	I2C_CAM1_CK	AJ7	I2C3_SCL
			P1	S2	I2C_CAM1_DAT	AJ6	I2C3_SDA
			P2	S3			
MIPI_CSI2_CLK_P	A23I	CSII_CK+	P3	S4			
MIPI_CSI2_CLK_N	B23	CSII_CK-	P4	S5	I2C_CAM0_CK	AH6	I2C2_SCL
			P5	S6	CAM_MCK	A4	GPIO1_IO14
			P6	S7	I2C_CAM0_DAT	AE8	I2C2_SDA
MIPI_CSI2_D0_P	A25	CSII_RX0+	P7	S8	CSIO_CK+	D22	MIPI_CSII_CLK_P
MIPI_CSI2_D0_N	B25	CSII_RX0-	P8	S9	CSIO_CK-	E22	MIPI_CSII_CLK_N
			P9	S10			
MIPI_CSI2_D1_P	A24	CSII_RX1+	P10	S11	CSIO_RX0+	D18	MIPI_CSII_D0_P
MIPI_CSI2_D1_N	B24	CSII_RX1-	P11	S12	CSIO_RX0-	E18	MIPI_CSII_D0_N
			P12	S13			
MIPI_CSI2_D2_P	A22	CSII_RX2+	P13	S14	CSIO_RX1+	D20	MIPI_CSII_D1_P
MIPI_CSI2_D2_N	B22	CSII_RX2-	P14	S15	CSIO_RX1-	E20	MIPI_CSII_D1_N
			P15	S16			
MIPI_CSI2_D3_P	A21	CSII_RX3+	P16	S17			

MIPI_CSI2_D3_N	B21	CSII_RX3-	P17	S18			
			P18	S19			
			P19	S20			
			P20	S21			
			P21	S22			
			P22	S23			
			P23	S24			
			P24	S25			
			P25	S26			
			P26	S27			
			P27	S28			
			P28	S29			
			P29	S30			
			P30	S31			
SAI5_RXC	AD14	SPIO_CSI#	P31	S32			
			P32	S33			
SD2_WP	AC26	SDIO_WP	P33	S34			
SD2_CMD	AB28	SDIO_CMD	P34	S35			
SD2_CD_B	AD29	SDIO_CD#	P35	S36			
SD2_CLK	AB29	SDIO_CK	P36	S37			
SD2_RESET_B	AD28	SDIO_PWR_EN	P37	S38	AUDIO_MCK	AJ15	SAI2_MCLK
			P38	S39	I2S0_LRCK	AJ17	SAI2_TXFS
SD2_DATA0	AC28	SDIO_D0	P39	S40	I2S0_SDOUT	AH16	SAI2_TXD0
SD2_DATA1	AC29	SDIO_D1	P40	S41	I2S0_SDIN	AJ14	SAI2_RXD0
SD2_DATA2	AA26	SDIO_D2	P41	S42	I2S0_CK	AH15	SAI2_TXC
SD2_DATA3	AA25	SDIO_D3	P42	S43			
ECSPI2_SS0	AJ22	SPIO_CS0#	P43	S44			
ECSPI2_SCLK	AH21	SPIO_CK	P44	S45			
ECSPI2_MISO	AH20	SPIO_DIN	P45	S46			

ECSPI2_MOSI	AJ21	SPIO_DO	P46	S47			
			P47	S48	I2C_GP_CK	AE18	SPDIF_TX
			P48	S49	I2C_GP_DAT	AD18	SPDIF_RX
			P49	S50	I2S2_LRCK	AC16	SAI3_TXFS
			P50	S51	I2S2_SDOUT	AH18	SAI3_TXD
			P51	S52	I2S2_SDIN	AF18	SAI3_RXD
			P52	S53	I2S2_CK	AH19	SAI3_TXC
			P53	S54			
NAND_CEO_B	L26	QSPI_CS0#	P54	S55			
NAND_READY_B	T28	QSPI_CS1#	P55	S56	QSPI_IO_2	L24	NAND_DATA02
NAND_ALE	N25	QSPI_CK	P56	S57	QSPI_IO_3	N24	NAND_DATA03
NAND_DATA01	L25	QSPI_IO_1	P57	S58			
NAND_DATA00	R25	QSPI_IO_0	P58	S59			
			P59	S60			
USB1_D_P	D10	USB0+	P60	S61			
USB1_D_N	E10	USB0-	P61	S62			
SAI1_TXD7 / GPIO1_IO12	AJ13 / A5	USB0_EN_OC#	P62	S63			
USB1_VBUS	A11	USB0_VBUS_DET	P63	S64			
GPIO1_IO10	B7	USB0_OTG_ID	P64	S65			
			P65	S66			
			P66	S67			
			P67	S68			
			P68	S69			
			P69	S70			
			P70	S71			
			P71	S72			
			P72	S73			
			P73	S74			
			P74	S75			

SDI_DATA5	AA29	PCIE_A_RST#	P75	S76
			P76	S77
3V3_RUN / SWDIO	N.A.	PCIE_B_CKREQ#	P77	S78
2C4_SCL	AF8	PCIE_A_CKREQ#	P78	S79
			P79	S80
			P80	S81
			P81	S82
			P82	S83
			P83	S84
			P84	S85
			P85	S86
PCIE_RXN_P	A14	PCIE_A_RX+	P86	S87
PCIE_RXN_N	B14	PCIE_A_RX-	P87	S88
			P88	S89
PCIE_TXN_P	A15	PCIE_A_TX+	P89	S90
PCIE_TXN_N	B15	PCIE_A_TX-	P90	S91
			P91	S92
HDMI_TX2_P	AH27	HDMI_D2+	P92	S93
HDMI_TX2_N	AJ27	HDMI_D2-	P93	S94
			P94	S95
HDMI_TX1_P	AH26	HDMI_D1+	P95	S96
HDMI_TX1_N	AJ26	HDMI_D1-	P96	S97
			P97	S98
HDMI_TX0_P	AH25	HDMI_D0+	P98	S99
HDMI_TX0_N	AJ25	HDMI_D0-	P99	S100
			P100	S101
HDMI_TXC_P	AH24	HDMI_CK+	P101	S102
HDMI_TXC_N	AJ24	HDMI_CK-	P102	S103
			P103	S104

HDMI_HPD	AE22	HDMI_HPD	P104	S105			
HDMI_DDC_SCL	AC22	HDMI_CTRL_CK	P105	S106			
HDMI_DDC_SDA	AF22	HDMI_CTRL_DAT	P106	S107			
			P107	S108	LVDS1_CK+	A28	LVDS1_CLK_P
			P108	S109	LVDS1_CK-	B28	LVDS1_CLK_N
			P109	S110			
			P110	S111	LVDS1_0+	A26	LVDS1_DO_P
			P111	S112	LVDS1_0-	B26	LVDS1_DO_N
			P112	S113			
GPIO1_IO11	D8	GPIO5 / PWM_OUT	P113	S114	LVDS1_1+	A27	LVDS1_DI_P
			P114	S115	LVDS1_1-	B27	LVDS1_DI_N
			P115	S116			
SAI2_RXC	AJ16	GPIO8	P116	S117	LVDS1_2+	B29	LVDS1_D2_P
SAI3_RXFS	AJ19	GPIO9	P117	S118	LVDS1_2-	C28	LVDS1_D2_N
SAI1_RXC	AH8	GPIO10	P118	S119			
SAI1_RXFS	AJ9	GPIO11	P119	S120	LVDS1_3+	C29	LVDS1_D3_P
			P120	S121	LVDS1_3-	D28	LVDS1_D3_N
I2C1_SCL	AC8	I2C_PM_CK	P121	S122	LCD1_BKLT_PWM	AJ20	SAI3_MCLK
I2C1_SDA	AH7	I2C_PM_DAT	P122	S123	GPIO13	B8	GPIO1_IO09
			P123	S124			
			P124	S125	LVDS0_0+ / eDPO_TX0+	D29 / N.A.	LVDS0_DO_P / N.A.
			P125	S126	LVDS0_0- / eDPO_TX0-	E28 / N.A.	LVDS0_DO_N / N.A.
			P126	S127	LCD0_BKLT_EN	A3	GPIO1_IO06
			P127	S128	LVDS0_1+ / eDPO_TX1+	E29 / N.A.	LVDS0_DI_P / N.A.
			P128	S129	LVDS0_1- / eDPO_TX1-	F28 / N.A.	LVDS0_DI_N / N.A.
UART2_TXD	AH4	SERO_TX	P129	S130			
UART2_RXD	AF6	SERO_RX	P130	S131	LVDS0_2+ / eDPO_TX2+	G29 / N.A.	LVDS0_D2_P / N.A.
SAI3_RXC	AJ18	SERO_RTS#	P131	S132	LVDS0_2- / eDPO_TX2-	H28 / N.A.	LVDS0_D2_N / N.A.
SD1_DATA4	U26	SERO_CTS#	P132	S133	LCD0_VDD_EN	AH17	SAI2_RXFS

			P133	SI34	LVDS0_CK+ / eDPO_AUX+	F29 / N.A.	LVDS0_CLK_P / N.A.
UART4_TXD	AH5	SER1_TX	P134	SI35	LVDS0_CK- eDPO_AUX+	/ G28 / N.A.	LVDS0_CLK_N / N.A.
UART4_RXD	AF5	SER1_RX	P135	SI36			
ECSP11_MOSI	AC20	SER2_TX	P136	SI37	LVDS0_3+ / eDPO_TX3+	H29 / N.A.	LVDS0_D3_P / N.A.
ECSP11_SCLK	AF20	SER2_RX	P137	SI38	LVDS0_3- / eDPO_TX3+	J28 / N.A.	LVDS0_D3_N / N.A.
ECSP11_MISO	AD20	SER2_RTS#	P138	SI39	I2C_LCD_CK	AH6	I2C2_SCL
ECSP11_SS0	AE20	SER2_CTS#	P139	SI40	I2C_LCD_DAT	AE8	I2C2_SDA
UART1_TXD	AJ3	SER3_TX	P140	SI41	LCD0_BKLT_PWM	AC18	SPDIF_EXT_CLK
UART1_RXD	AD6	SER3_RX	P141	SI42	GPIO12	A8	GPIO1_IO08
			P142	SI43			
SAI5_RXD1	AD16	CANO_TX	P143	SI44			
SAI5_RXD2	AF16	CANO_RX	P144	SI45			
SAI5_RXD3	AE14	CANI_TX	P145	SI46			
SAI5_MCLK	AF14	CANI_RX	P146	SI47			
				SI48			
				SI49			
				SI50			
				SI51			
				SI52			
				SI53			
				SI54			
				SI55			
				SI56			
				SI57			
				SI58			

4.2 Thermal Design

Highly integrated modules like SOM-SMARC-MX8M-PLUS offer very high performance within small dimensions. On the other hand, the miniaturization of ICs and the high operating frequencies of the processors lead to high heat generation that must be dissipated in order to maintain the CPU within its allowed temperature range.

The operating temperature specified in the Technical Features of SOM-SMARC-MX8M-PLUS module indicates the temperature range in which any and all parts of the heat spreader / heat sink must remain, in order for SECO to guarantee functionality. Hence, these numbers do not necessarily indicate the suitable environmental temperature.

The heat spreader is not intended to be a guaranteed standalone cooling system, but should be used only as a supplemental means of transferring heat to another dissipation system (i.e. heat sinks, fans, heat pipes etc).

It is the customer's responsibility to design and apply an application-dependent cooling system, capable of ensuring that the heat spreader / heat sink temperature remain within the indicated range of the module.

It is an absolute requirement that the customer, after thorough evaluation of the processor's workload in the actual system application, the system enclosure and consequent air flow/Thermal analysis, accurately study and develop a suitable cooling solution for the assembled system.

SECO can provide SOM-SMARC-MX8M-PLUS module specific heatspreaders and heatsinks, but please remember that their use must be evaluated accurately inside the final system, and that they should be used only as a part of a more comprehensive ad-hoc cooling solutions.

Ordering Code	Description
RD18-DISS-1-PK	SMARC® HEAT SPREADER: SOM-SMARC-MX8M-PLUS Heat Spreader (PASSIVE) - Packaged
RD18-DISS-2-PK	SMARC® HEAT SINK: SOM-SMARC-MX8M-PLUS Heat Sink (PASSIVE) - Packaged



Warning!

The thermal solutions available with SECO boards are tested in the commercial temperature range (0-60°C), without housing and inside climatic chamber. Therefore, the customer is suggested to study, develop and validate the cooling solution for his system, considering ambient temperature, processor's workload, utilisation scenarios, enclosures, air flow and so on.

In particular, the heatspreader is not intended to be a cooling system by itself, but only as the standard means for transferring heat to cooler, like heatsinks, cold plate, heat pipes and so on.



SECO S.p.A. - Via A. Grandi, 20
52100 Arezzo - ITALY
Ph: +39 0575 26979 - Fax: +39 0575 350210
www.seco.com



SOM-SMARC-MX8M-Plus

SOM_SMARC-MX8M Plus User Manual - Rev. First Edition: 1.0 - Last Edition: 1.3 - Author: S.O. - Reviewed by N.P. - Copyright © 2024 SECO S.p.A.